

McKinsey  
Global Institute

# Agents, robots, and us: Skill partnerships in the age of AI

**Authors**

Lareina Yee  
Anu Madgavkar  
Sven Smit  
Alexis Krivkovich  
Michael Chui  
Maria Jesus Ramirez  
Diego Castresana



November 2025

Confidential and proprietary. Any use of this material without specific permission of McKinsey & Company is strictly prohibited.

Copyright © 2025 McKinsey & Company.  
All rights reserved.  
Cover image © XH4D/Getty Images.  
All interior images © Getty Images.

# McKinsey Global Institute

The McKinsey Global Institute was established in 1990. Our mission is to provide a fact base to aid decision making on the economic and business issues most critical to the world's companies and policy leaders. We benefit from the full range of McKinsey's regional, sectoral, and functional knowledge, skills, and expertise, but editorial direction and decisions are solely the responsibility of MGI directors and partners.

Our research is currently grouped into five major themes:

- Productivity and prosperity: Creating and harnessing the world's assets most productively
- Resources of the world: Building, powering, and feeding the world sustainably
- Human potential: Maximizing and achieving the potential of human talent
- Global connections: Exploring how flows of goods, services, people, capital, and ideas shape economies
- Technologies and markets of the future: Discussing the next big arenas of value and competition

We aim for independent and fact-based research. None of our work is commissioned or funded by any business, government, or other institution; we share our results publicly free of charge; and we are entirely funded by the partners of McKinsey. While we engage multiple distinguished external advisers to contribute to our work, the analyses presented in our publications are MGI's alone, and any errors are our own.

You can find out more about MGI and our research at [www.mckinsey.com/mgi](http://www.mckinsey.com/mgi).

## **MGI directors**

Sven Smit (chair)  
Chris Bradley  
Kweilin Ellingrud  
Sylvain Johansson  
Nick Leung  
Olivia White  
Lareina Yee

## **MGI partners**

Mekala Krishnan  
Anu Madgavkar  
Jan Mischke  
Jeongmin Seong

# Contents

At a glance 3

Introduction 4

## CHAPTER 1

**The workforce of the future will be a partnership of people, agents, and robots 7**

## CHAPTER 2

**Human skills will evolve, not disappear, as people work closely with AI 21**

## CHAPTER 3

**Entire workflows can be reimaged around people, agents, and robots 35**

## CHAPTER 4

**Leadership is crucial as agents and robots reshape work and the economy 52**

Glossary of terms 55

Acknowledgments 56

Endnotes 57

# At a glance

- **Work in the future will be a partnership between people, agents, and robots—all powered by AI.** Today's technologies could theoretically automate more than half of current US work hours. This reflects how profoundly work may change, but it is not a forecast of job losses. Adoption will take time. As it unfolds, some roles will shrink, others grow or shift, while new ones emerge—with work increasingly centered on collaboration between humans and intelligent machines.
- **Most human skills will endure, though they will be applied differently.** More than 70 percent of the skills sought by employers today are used in both automatable and non-automatable work. This overlap means most skills remain relevant, but how and where they are used will evolve.
- **Our new Skill Change Index shows which skills will be most and least exposed to automation in the next five years.** Digital and information-processing skills could be most affected; those related to assisting and caring are likely to change the least.
- **Demand for AI fluency—the ability to use and manage AI tools—has grown sevenfold in two years,** faster than for any other skill in US job postings. The surge is visible across industries and likely marks the beginning of much bigger changes ahead.
- **By 2030, about \$2.9 trillion of economic value could be unlocked in the United States**—if organizations prepare their people and redesign workflows, rather than individual tasks, around people, agents, and robots working together.

# Introduction

**Work in the future** will be a partnership between people, agents, and robots—all powered by artificial intelligence. While much of the current public debate revolves around whether AI will lead to sweeping job losses, our focus is on how it will change the very building blocks of work—the skills that underpin productivity and growth. Our research suggests that although people may be shifted out of some work activities, many of their skills will remain essential. They will also be central in guiding and collaborating with AI, a change that is already redefining many roles across the economy.

In this research, we use “agents” and “robots” as broad, practical terms to describe all machines that can automate nonphysical and physical work, respectively. Many different technologies perform these functions, some based on AI and others not, with the boundaries between them fluid and changing. Using the terms in this expansive way lets us analyze how automation reshapes work overall.<sup>1</sup>

This report builds on McKinsey’s long-running research on automation and the future of work. Earlier studies examined individual activities, while this analysis also looks at how AI will transform entire workflows and what this means for skills. New forms of collaboration are emerging, creating skill partnerships between people and AI that raise demand for complementary human capabilities.

Although the analysis focuses on the United States, many of the patterns it reveals—and their implications for employers, workers, and leaders—apply broadly to other advanced economies.

We find that currently demonstrated technologies could, in theory, automate activities accounting for about 57 percent of US work hours today.<sup>2</sup> This estimate reflects the technical potential for change in what people do, not a forecast of job losses. As technologies take on more complex sequences of tasks, people will remain vital to make them work effectively and to do what machines cannot. Our assessment reflects today’s capabilities, which will continue to evolve, and adoption may take decades.

AI will not make most human skills obsolete, but it will change how they are used. We estimate that more than 70 percent of today’s skills can be applied in both automatable and non-automatable work. With AI handling more common tasks, people will apply their skills in new contexts. Workers will spend less time preparing documents and doing basic research, for example, and more time framing questions and interpreting results. Employers may increasingly prize skills that add value to AI.

To measure how skills could evolve, we developed a Skill Change Index (SCI), a time-weighted measure of automation’s potential impact on each skill used in today’s workforce. Nearly every occupation will experience skill shifts by 2030. Highly specialized, automatable skills such as accounting and coding could face the greatest disruption, while interpersonal skills like negotiation and coaching may change the least. Most others, including widely applicable skills such as problem solving and communication, may evolve as part of a growing partnership with agents and robots.

Employers are already adjusting. Demand for AI fluency—the ability to use and manage AI tools—has jumped nearly sevenfold in two years. The need for technical AI skills employed to develop and govern AI systems is also growing, though at a slower pace. About eight million people in the United States work in occupations where job postings already call for at least one AI-related skill—a fraction of what may be needed in the years ahead. Demand is also rising for complementary skills such as quality assurance, process optimization, and teaching, as well as for some physical skills such as nursing and electrical work. In contrast, job post mentions are declining for routine writing and research, both areas where AI already performs well, although these skills remain essential for much of the workforce.

In our midpoint scenario of automation adoption by 2030, AI-powered agents and robots could generate about \$2.9 trillion in US economic value per year.<sup>3</sup> Capturing this may depend less on new technological breakthroughs than on how organizations redesign workflows—especially complex, high-value ones that rely on unstructured data—and how quickly human skills adapt. Integrating AI will not be a simple technology rollout but a reimagining of work itself—redesigning processes, roles, skills, culture, and metrics so people, agents, and robots create more value together.

Leaders will play a central role in shaping this partnership. The most effective will engage directly with AI rather than delegating, invest in the human skills that matter most, and balance gains with responsibility, safety, and trust. The outcomes for firms, workers, and communities will ultimately depend on how organizations and institutions work together to prepare people for the jobs of the future.



# The workforce of the future will be a partnership of people, agents, and robots

AI is redefining the boundaries of work and unlocking new potential for productivity.<sup>4</sup> Work will be reconfigured as a partnership between people, agents, and robots.<sup>5</sup>

## **AI has made agents and robots more autonomous and capable**

For much of the past century, machines have been built to follow rules. Robots executed physical routines like assembling parts while software automated predictable clerical and analytical tasks. Both types of machines operated in a predetermined way; they did what they were programmed to do, and little more. The rise of AI has begun to change that and to broaden the scope of what automation can do. (See sidebar “How technology is advancing.”)

AI agents and robots—machines that perform cognitive and physical work, respectively—are becoming more capable as they learn from vast data sets. This enables them to simulate reasoning and to respond to a wider range of inputs, including natural language, and adapt to different contexts instead of simply following preset rules.

We estimate that today’s technology could, in theory, automate about 57 percent of current US work hours (Exhibit 1). This figure compares the capabilities of existing technologies, including those demonstrated in a lab, with the level of human proficiency required for different work tasks.<sup>6</sup> As technology advances, the picture will continue to evolve and should be updated regularly.

Actual *adoption* depends on more than technical capability. Factors including policy choices, labor costs, implementation expenses, and development time all influence when and where automation is deployed. Electricity took more than 30 years to spread, and industrial robotics followed a similar multi-decade path. As recently as 2023, only about one in five companies ran most of their applications in the cloud, despite the technology being widely available since the mid-2000s.<sup>7</sup> (See the technical appendix for details.)

In this chapter, we focus on *technical automation potential*—mapping the frontier of what today’s technologies can do and identifying the types of work that could be most affected in the years ahead.

## Sidebar

### How technology is advancing

**Rapid advances** in model reasoning and computing power have dramatically accelerated AI's progress. AI models trained to simulate reasoning are integrating disparate structured and unstructured data sources, executing multistep processes, and able to match human performance in high school and university standardized exams across multiple subjects. At the same time, the advent and enhancement of graphics processing units (GPU) and tensor processing units (TPU) are making model training and inference faster, cheaper, and more energy efficient. AI has also become multimodal, able to ingest and generate text, audio, images, and video, and it is increasingly interoperable

across tools and platforms. For example, Model Context Protocol and Agent2Agent are protocols that allow teams of agents to communicate. Important challenges remain, however, particularly regarding hallucinations, transparency, and explainability, which are key to ensuring safety and avoiding unwanted bias.<sup>1</sup> The underlying infrastructure to support AI is also advancing quickly from GPU and TPU to the rapid build-out of AI data centers, and new techniques to use traditional and alternative sources of energy.

#### AI-powered agents as teammates

Developments in AI are transforming agents from passive assistants into “virtual coworkers,” with improving cognitive capabilities that can increasingly autonomously plan and execute complex tasks in workflows.<sup>2</sup> AI agents are beginning

to carry out multistep processes such as interacting with customers, processing transactions, and coordinating follow-up actions. This marks a fundamental step toward AI-driven operations, where people and AI-powered agents collaborate as a team to deliver results more quickly and efficiently.<sup>3</sup>

#### AI-powered robots are becoming more capable

A new generation of general-purpose robots is emerging. Powered by AI, they integrate spatial perception, reasoning, and action to perform complex physical activities such as operating in unstructured environments, following verbal instructions, and executing variations on tasks for which they were not explicitly trained. Technological advances in robotics extend beyond AI to include improvements in dexterity, sensing, and edge computing.<sup>4</sup>

<sup>1</sup> Ivan Solovyev and Shrestha Basu Mallick, “Gemini 2.0: Level up your apps with real-time multimodal interactions,” Google, December 2024.

<sup>2</sup> *McKinsey technology trends outlook 2025*, McKinsey, July 2025.

<sup>3</sup> Marc Benioff, “How the rise of new digital workers will lead to an unlimited age,” *Time*, November 25, 2024.

<sup>4</sup> “A leap in automation: The new technology behind general-purpose robots,” McKinsey, July 2025.

## AI can have an impact on all types of work

We distinguish between *physical* and *nonphysical* work. Robots are needed to automate the former, agents the latter. Not all automation requires agents or robots in the narrow technical sense of those terms, but we use them broadly to capture the full range of technologies that automate work.

Nonphysical work accounts for about two-thirds of US work hours. Roughly one-third of those hours draw on social and emotional skills that mostly remain beyond AI's reach, while the rest involve tasks—such as reasoning and information processing—that are better suited to automation. These more automatable activities represent about 40 percent of total US wages and span roles in fields from education and healthcare to business and legal (Exhibit 1).

The near-term influence of automation on physical work may be narrower. Activities that require physical as well as cognitive capabilities account for about 35 percent of current US work hours. Robots have made major progress, but most physical work still demands fine motor skills, dexterity, and situational awareness that technology cannot yet replicate reliably (see sidebar “Robots in the workplace”).

## Two-thirds of US work hours require only nonphysical capabilities.

### Distribution of physical and nonphysical work in the US, by occupation group

Capabilities required:<sup>1</sup> ■ Physical ■ Nonphysical ■ Share of work that requires social and emotional capabilities

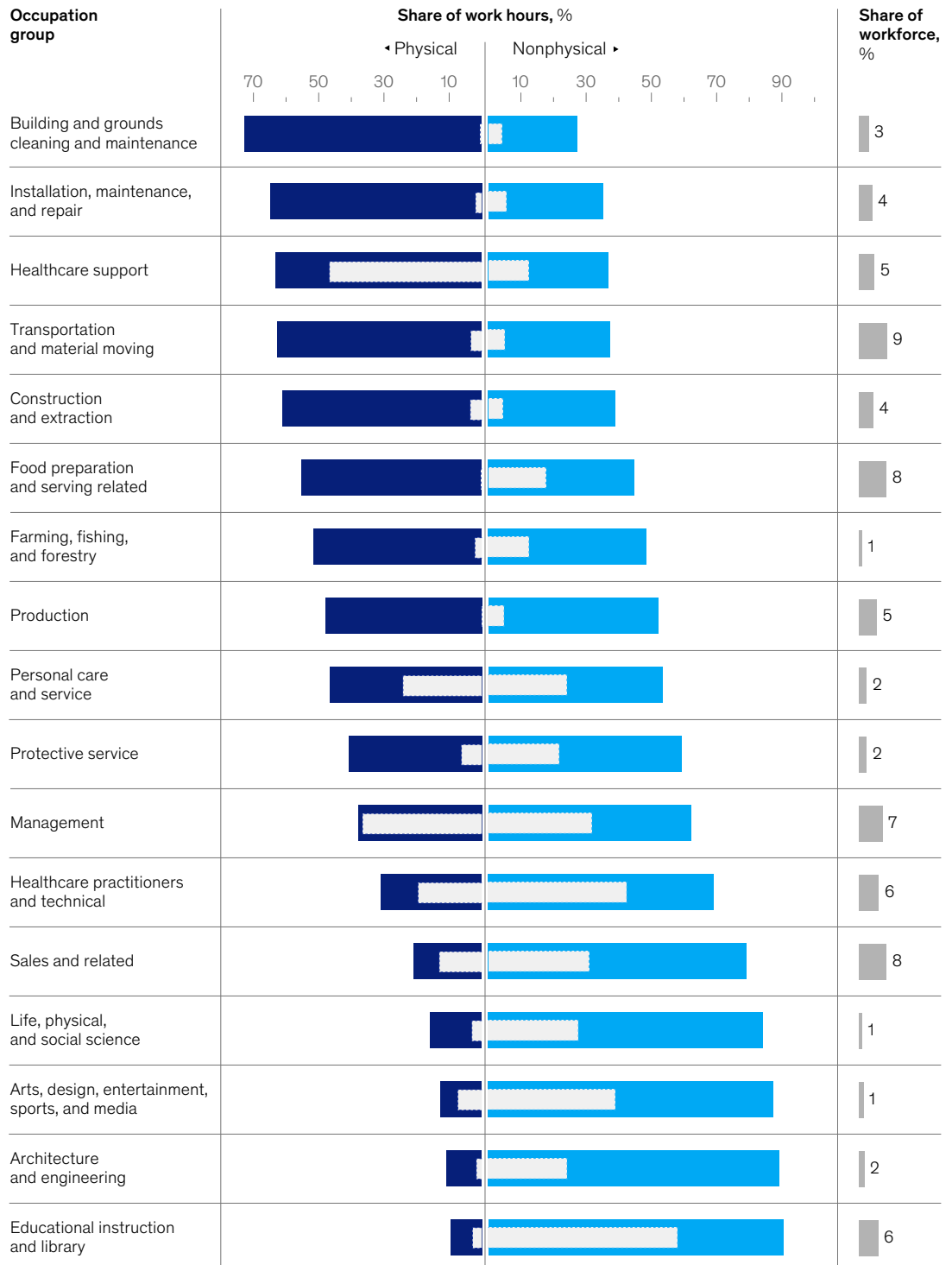

## Two-thirds of US work hours require only nonphysical capabilities.

### Distribution of physical and nonphysical work in the US, by occupation group

Capabilities required:<sup>1</sup> ■ Physical ■ Nonphysical ■ Share of work that requires social and emotional capabilities

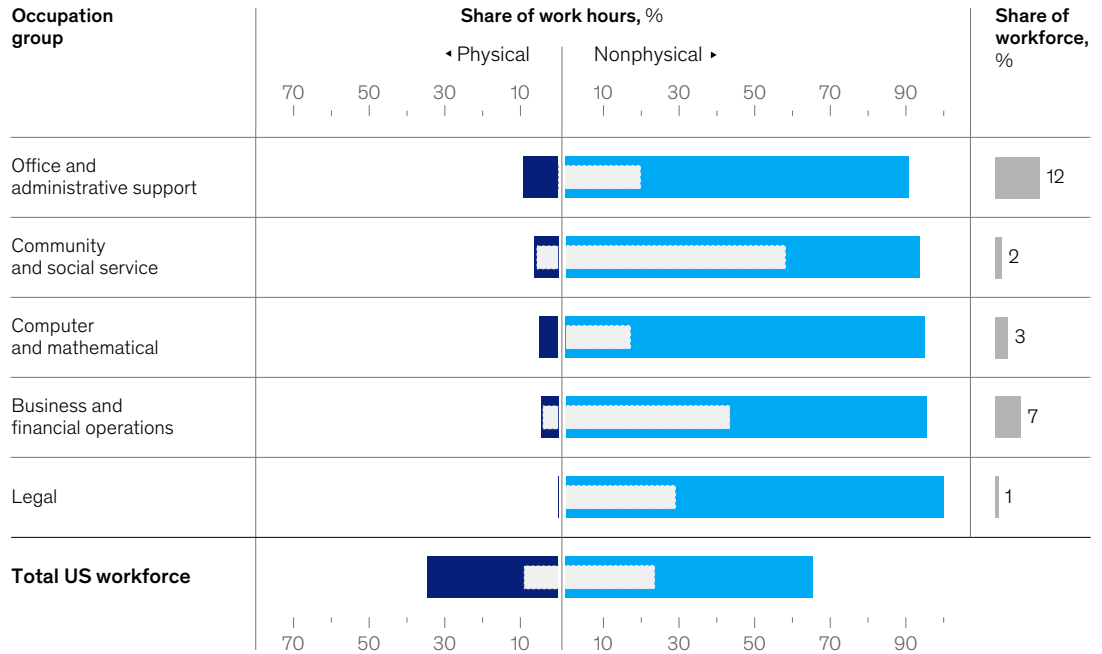

<sup>1</sup>All work requires cognitive capabilities. Both physical and nonphysical work may also require social and emotional capabilities.  
Source: Lightcast; US Bureau of Labor Statistics (2024); McKinsey Global Institute analysis

McKinsey & Company

Even so, the effects could be significant for some workers. Physical tasks make up more than half of working hours for about 40 percent of the US workforce, including drivers, construction workers, cooks, and healthcare aides. Advances in robotics are expected to change occupations in areas like production and food preparation, including some lower-wage roles. Robots may also continue to perform work that is hazardous or otherwise unfeasible for people, such as underwater tasks, search-and-rescue, and inspections of dangerous environments.

## Sidebar

### Robots in the workplace

**Robots have been around** for decades, but advances in AI are giving them capabilities once considered beyond the reach of automation. This progress is being driven by embodied AI—the integration of intelligence and physicality that enables robots to perceive, reason, and act increasingly autonomously.

Robots today take many forms, depending on their application. They range from autonomous vehicles that navigate roads to drones used for inspection or delivery to disk-shaped machines with wheels that clean floors or move goods in warehouses. Typical delivery robots are roughly cube shaped, while quadruped robots that resemble animals can navigate rough terrain.

Among these, humanoid robots continue to capture the imagination with their relatable appearance, fueling growing interest, new market entrants, significant investment, and widespread public fascination through videos showcasing their capabilities.<sup>1</sup> In principle, humanoids offer practical physical advantages. They can operate in physical spaces designed for people, reducing the need for costly reconfiguration.<sup>2</sup>

Yet major hurdles remain. Chief among them are dexterity and mobility, requiring advances in actuators, mechanical range, and sensorimotor control. Safety is another barrier to scale, particularly when AI models are employed to control robots in the presence of humans, demanding both regulatory clarity and technical progress in collision avoidance, malfunction prevention,

cybersecurity, and transparency in AI decision-making. Power is also a limitation: Most humanoids can operate untethered for only two to four hours per charge. Even if performance improves, affordability may be difficult to achieve—per-unit costs of advanced, safe models would need to fall from today's \$150,000–\$500,000 range in the United States to roughly \$20,000–\$50,000 to enable large-scale adoption.<sup>3</sup>

Mass adoption of humanoid robots in workplaces hinges on overcoming these challenges, but the investment and experimentation now underway are advancing the entire field and heightening awareness of potential applications. Meanwhile, nonhumanoid designs will continue to proliferate, growing fast in volume and variety.

<sup>1</sup> *The Humanoid 100: Mapping the humanoid robot value chain*, Morgan Stanley, February 2025.

<sup>2</sup> "Will embodied AI create robotic coworkers?" McKinsey, June 2025.

<sup>3</sup> "Humanoid robots: Crossing the chasm from concept to commercial reality," McKinsey, October 2025.

### AI-powered automation will change work, but people remain indispensable

At current levels of capability, agents could perform tasks that occupy 44 percent of US work hours today, and robots 13 percent (Exhibit 2).<sup>8</sup>

This means that automation could, in theory, take on a majority of the work now done by people in the United States. That does not mean half of all jobs would disappear; many would change as specific tasks are automated, shifting what people do rather than eliminating the work itself.

In addition, work that draws heavily on social and emotional skills remains largely beyond the reach of automation even under a full-adoption scenario. This is because many tasks require real-time awareness such as a teacher reading a student's expression or a salesperson sensing when a client is losing interest. People also provide oversight, quality control, and the human presence that customers, students, and patients often prefer.

Extending automation further would require technologies that can match a range of human capabilities currently unmatched. Agents would need to interpret intention and emotion. Robots would need to master fine motor control, such as grasping delicate objects or manipulating instruments in surgery.

## People, agents, and robots could all play significant roles in the workforce of the future.

Distribution of work hours in the US, by technical automation potential, 2024, %

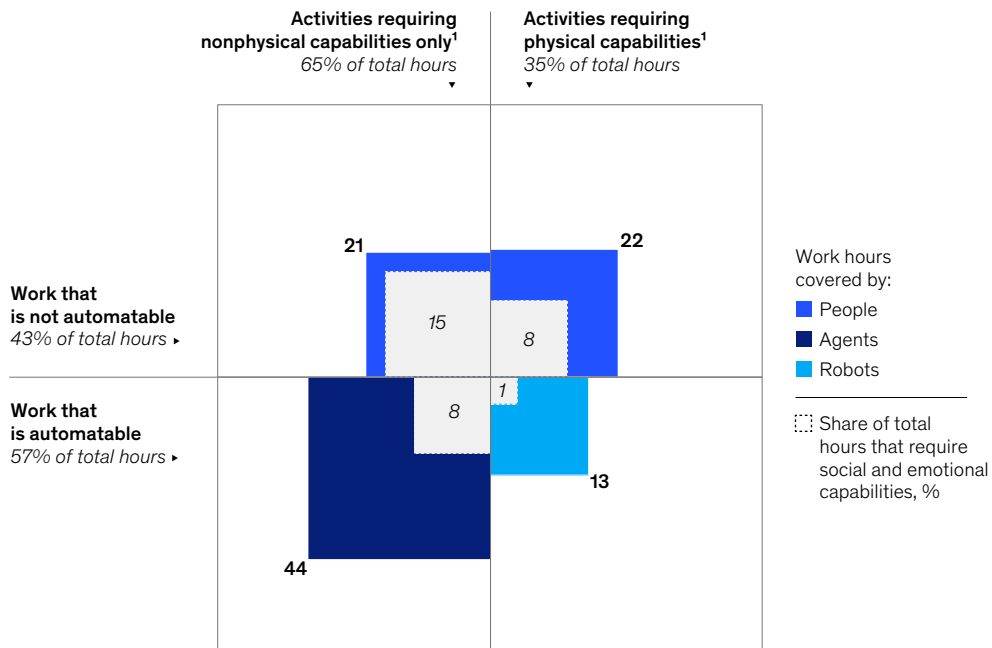

Note: Technical automation potential shown is the late scenario of expert estimates. The early scenario of technical automation potential in the US is 65% of current work hours. In this research, we use "agents" and "robots" as broad, practical terms to describe all machines that can automate nonphysical and physical work, respectively. Many different technologies perform these functions, some based on AI and others not, with the boundaries between them fluid and changing. Using the terms in this inclusive way lets us analyze how automation reshapes work overall.

<sup>1</sup>All work requires cognitive capabilities. Both physical and nonphysical work may also require social and emotional capabilities.  
 Source: US Bureau of Labor Statistics; O\*NET; Current Population Survey, US Census Bureau; McKinsey Global Institute analysis

McKinsey & Company

As technology advances, the work requiring people will also change. Some roles will shrink, others expand or shift focus, and new ones will be created. Recent developments in radiology illustrate this dynamic. Between 2017 and 2024, radiologist employment grew by about 3 percent per year despite rapid advances in AI, and it is expected to continue growing.<sup>9</sup> AI augmented radiologists' work, improving accuracy and efficiency while enabling doctors to focus on complex decision-making and patient care.<sup>10</sup> The Mayo Clinic, for example, has expanded its radiology staff by more than 50 percent since 2016 while deploying hundreds of AI models to support image analysis.<sup>11</sup>

AI is also creating other new types of work and roles. Software engineers are building and refining agents, while designers and creators are using generative tools to produce new content.

## Framing the jobs debate as AI reshapes work

**The impact of AI** on jobs remains uncertain. While many studies attempt to estimate potential job gains or losses, our focus is on how technology is changing the *content* of work and the *skills* people need, rather than on how many jobs may ultimately be gained or lost.

History suggests that although technology has displaced workers in the short term, the economy has generated additional demand for labor, including new roles and industries, over time. The breadth of AI's capabilities—its reach into reasoning, communication, and judgment—has heightened concern about the future of work. To frame the debate, we explore what the current research can and cannot tell us through four guiding questions.

### How close are AI agents and robots to matching all economically relevant human capabilities?

AI is encroaching on work once considered beyond automation, extending into reasoning, communication, and judgment—skills that underpin most jobs in the modern economy.<sup>1</sup> Despite these advances, AI still lacks many distinctly human abilities, leaving ample room for human labor to thrive. To match people entirely, machines would need to generalize and adapt across contexts, demonstrate advanced fine motor skills, coordinate reliably at scale, exercise social

and moral judgment, and take responsibility for outcomes, all at acceptable cost and risk.<sup>2</sup> And beyond the technical automation potential, actual adoption rates depend on factors such as solution timelines, technology versus labor costs, and the speed at which technologies diffuse from introduction to widespread use.

### Will a more AI-centric economy create enough jobs?

The US economy has created tens of millions of jobs this century, and projections from the US Bureau of Labor Statistics and World Economic Forum point to continued employment growth over the next five to ten years.<sup>3</sup> A key issue is whether new jobs will come quickly enough, and in sufficient numbers, to absorb jobs that are displaced—and whether those jobs will have similar conditions. While this is beyond the scope of our analysis, past economic transformations—from the Industrial Revolution to the rise of the internet—offer clues: Technology has often eliminated jobs, sometimes massively and sometimes depressing wages in certain areas, but has ultimately catalyzed new industries and roles over time.<sup>4</sup>

Early evidence suggests that AI may follow that familiar trajectory. Hiring has reportedly slowed for entry-level programmers and analysts—in other words, workers whose tasks AI is particularly adept at performing.<sup>5</sup> At the same time, new forms of work are emerging. Companies are hiring agent product managers, AI evaluation writers,

and “human in the loop” validators to guide machine output. New markets are also expanding, from data center construction to AI infrastructure maintenance, while broader structural trends are generating jobs in sectors where automation faces natural limits, such as healthcare and personal services.<sup>6</sup>

### How might the composition of work change?

Studies link the spread of industrial robots to localized job losses and worker displacement, suggesting that automation waves have depressed employment and wages before new roles emerge.<sup>7</sup> The college wage premium has been flat since around 2010, while posted salaries for knowledge jobs have plateaued since mid-2024.<sup>8</sup> Enrollment in vocational programs and apprenticeships is rising, as is investment in construction, manufacturing, and energy projects, hinting at a more complex labor story than simple substitution and pressure on wages.<sup>9</sup>

### Will we adapt fast enough?

Studies suggest that retraining programs, social safety nets, and education systems are not yet ready to handle widespread automation. According to the OECD, participation in adult-learning and reskilling programs is flat or falling in many countries.<sup>10</sup> Although 77 percent of companies say they intend to launch upskilling or reskilling initiatives, follow-through may be limited because employers recognize that workers often move on after gaining new skills.<sup>11</sup>

<sup>1</sup> “Claude 3.5 Sonnet,” Anthropic, June 2024.

<sup>2</sup> Danny Driess et al., *Learning geometric reasoning and control for long-horizon tasks from visual input*, 2021 IEEE International Conference on Robotics and Automation (ICRA), January 2021.

<sup>3</sup> “Employment situation news release,” US Bureau of Labor Statistics, August 2025; and *The future of jobs report 2025*, World Economic Forum, January 2025.

<sup>4</sup> Paul Gaggl et al., *Does electricity drive structural transformation? Evidence from the United States*, National Bureau of Economic Research, working paper number 26477, November 2019; and Sun Ling Wang et al., *Farm labor, human capital, and agricultural productivity in the United States*, US Department of Agriculture, February 2022.

<sup>5</sup> Eric Brynjolfsson et al., “Canaries in the Coal Mine? Six Facts about the Recent Employment Effects of Artificial Intelligence,” Stanford Digital Economy Lab, August 2025.

<sup>6</sup> “Beyond the numbers,” US Bureau of Labor Statistics, August 2025; “Ageing,” United Nations Population Fund, June 2024; *U.S. energy and employment report 2024*, US Department of Energy, 2024; *Heartbeat of health: Reimagining the healthcare workforce of the future*, McKinsey Health Institute, May 2025.

<sup>7</sup> Daron Acemoglu and Pascual Restrepo, *Robots and jobs: Evidence from US labor markets*, National Bureau of Economic Research, working paper number 23285, March 2017; William F. Maloney and Carlos Molina, *Is automation labor-displacing in the developing countries, too? Robots, polarization, and jobs*, World Bank, July 2019; and Erik Brynjolfsson, Bharat Chandar, and Ruyu Chen, *Canaries in the coal mine? Six facts about the recent employment effects of artificial intelligence*, Stanford, August 2025.

<sup>8</sup> Stephen J. Kline and Nathan Rosenberg, “An overview of innovation,” in *Studies on Science and the Innovation Process*, World Scientific, 2009.

<sup>9</sup> “Ageing,” United Nations Population Fund, June 2024; and *U.S. energy and employment report 2024*, US Department of Energy, 2024.

<sup>10</sup> Chad P. Brown and Caroline Freund, *Active labor market policies: Lessons from other countries for the United States*, Peterson Institute for International Economics, January 2019.

<sup>11</sup> *The future of jobs report 2025*, World Economic Forum, January 2025.

Sidebar (continued)

## Framing the jobs debate as AI reshapes work

There are also signs of adaptation. About 75 percent of knowledge workers already

use AI tools in some form, even when their companies have not formally deployed them.<sup>12</sup>

Whether AI proves to create or reduce net jobs depends on how effectively it is used to build new industries and markets—and on

how well people and institutions adapt to them. AI can also assist on that front, helping identify emerging occupations, map the skills they require, and support workers through personalized guidance, training, and job matching.<sup>13</sup>

---

<sup>12</sup> 2024 work trend index annual report, Microsoft, May 2024.

<sup>13</sup> AI could enhance many stages of workforce development, such as automating routine assessments, tailoring training to individual needs, and matching people to new opportunities. It could also personalize learning through adaptive content and simulations, build soft skills through virtual practice, and connect workers to roles aligned with their strengths.

Overall US demand for labor has remained strong through multiple waves of automation, with new activities having been created faster than technology replaced existing ones.<sup>12</sup> Yet AI's broad reach raises concern that this time may be different. The outcome will depend on whether new demand, industries, and roles emerge to absorb displaced workers—a question beyond the scope of this research. If history is a guide, employment is likely to evolve rather than contract, although there is no certainty that AI will follow the same pattern (see sidebar “Framing the jobs debate as AI reshapes work”).

## The mix of people, agents, and robots varies across a spectrum of seven archetypes

The overall level of employment and mix of occupations in the economy depend on how industries evolve. Within occupations, the configuration of work differs markedly based on their reliance on physical, cognitive, and social and emotional capabilities.

To understand the variation, we analyzed roughly 800 occupations and grouped them according to their physical and nonphysical automation potential.<sup>13</sup> This exercise yields seven archetypes that show how people, agents, and robots could collaborate.

## Occupations fall into distinct archetypes based on the potential role of people, agents, and robots.

Occupation archetypes' distribution of work hours in the US, by technical automation potential, 2024, %

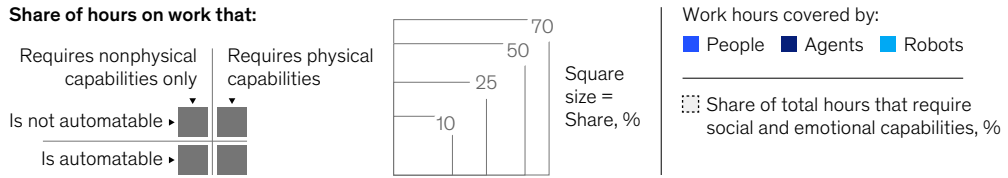

Less automatable ← → More automatable

### PEOPLE-CENTRIC

Future work done mostly by people

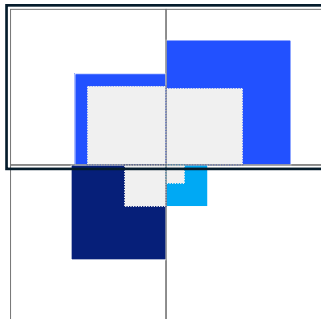

34% of people in current US workforce are in occupations that could fit this archetype  
**\$71,000** average pay  
 Examples: Registered nurses, psychologists, firefighters

### PEOPLE-AGENT

Future work done mostly by people with agents

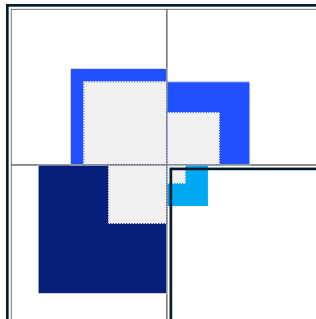

21% in current workforce  
**\$74,000** average pay  
 Examples: Sales reps, secondary school teachers, HR specialists

### AGENT-CENTRIC

Future work done mostly by agents

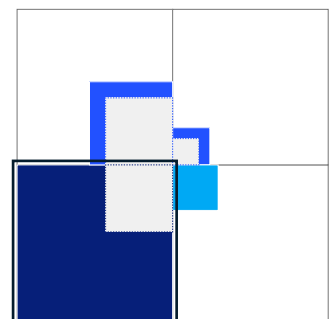

30% in current workforce  
**\$70,000** average pay  
 Examples: Accountants, software developers, lawyers

### PEOPLE-ROBOT

Future work done mostly by people with robots

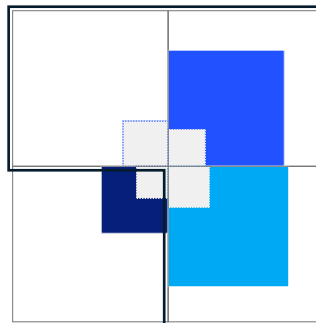

<1% in current workforce  
**\$54,000** average pay  
 Examples: Insulation workers, drywall and ceiling-tile installers

### ROBOT-CENTRIC

Future work done mostly by robots

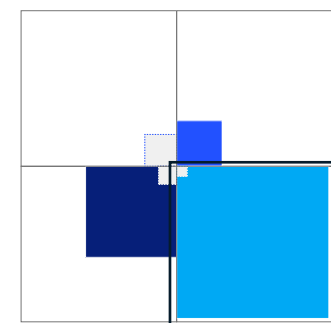

8% in current workforce  
**\$42,000** average pay  
 Examples: Stockers and order fillers, welders, cooks

## Occupations fall into distinct archetypes based on the potential role of people, agents, and robots.

### Occupation archetypes' distribution of work hours in the US, by technical automation potential, 2024, %

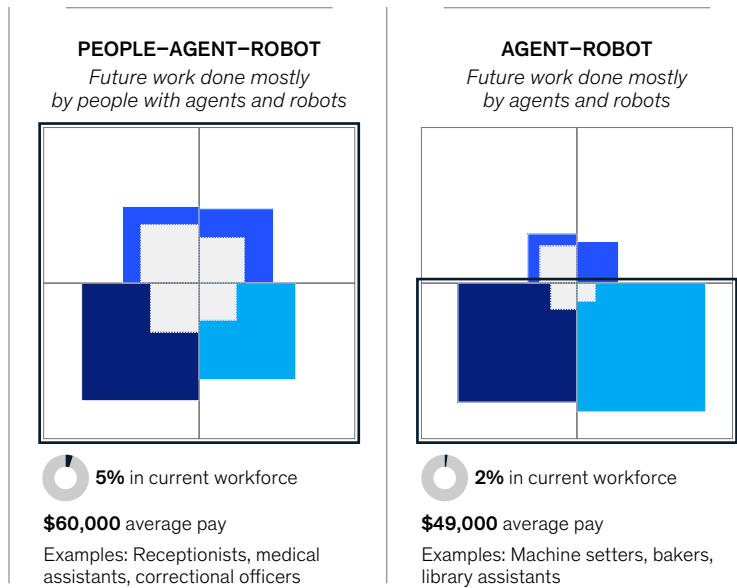
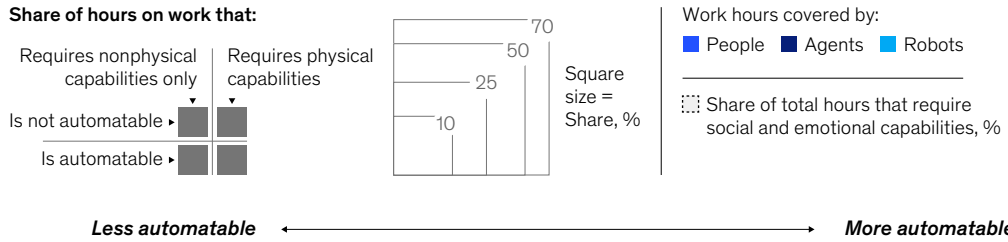

Note: Technical automation potential shown is in 2024, in the late scenario of expert estimates. The early scenario of technical automation potential in the US is 65% of current work hours. Average pay is based on 2024 data from the US Bureau of Labor Statistics and includes only wages and salaries. In this research, we use "agents" and "robots" as broad, practical terms to describe all machines that can automate nonphysical and physical work, respectively. Many different technologies perform these functions, some based on AI and others not, with the boundaries between them fluid and changing. Using the terms in this inclusive way lets us analyze how automation reshapes work overall.  
 Source: US Bureau of Labor Statistics; O\*NET; Current Population Survey, US Census Bureau; McKinsey Global Institute analysis

Occupations with the lowest automation potential were classified as *people-centric*, while those with high shares of automatable tasks were labeled *agent-centric* or *robot-centric*. Roles with a more even balance were grouped into mixed or hybrid archetypes that combine substantial shares of two or all three (Exhibit 3).

This framework applies across labor markets and can help leaders see where change may come first and how workforce transitions could unfold, highlighting roles that may evolve into human–agent–robot coworker models and those likely to be largely automated by agents or robots under human supervision. For workers, it offers a view of how their own roles might change.

At one end of the spectrum are roles that remain largely human. These people-centric occupations—found, for example, in healthcare and in building and maintenance—make up about one-third of US jobs and pay an average of \$71,000 a year. Physical activity that current technologies cannot replicate accounts for about half of the work hours in these occupations.<sup>14</sup>

At the other end of the spectrum are roles with the highest potential for automation by agents or robots. These occupations make up about 40 percent of total jobs. With average pay of \$70,000, most are agent-centric roles in legal and administrative services. They involve large shares of cognitive tasks—such as drafting documents—that could technically be handled by AI systems. Some of this work may end up being fully automated, but people will still be needed to guide, supervise, and verify.

A smaller subset of these highly automatable jobs involves physical work. These robot-centric roles—such as drivers and machine operators—are physically demanding, sometimes hazardous, and typically pay about \$42,000 a year. In theory, they could be almost fully automated, but cost and other real-world constraints may keep people in the loop.

Agent–robot roles form an even smaller category, accounting for only about 2 percent of workers. They pay roughly \$49,000, and physical tasks occupy 53 percent of work time. These jobs appear mainly in production settings where software intelligence directs physical systems, such as automated manufacturing or logistics operations.

Between the extremes lies a diverse set of occupations that combine humans, agents, and robots. These hybrid roles employ about one-third of the workforce and differ significantly in pay, physical intensity, and automation potential—yet people remain essential in every setting. As automation is adopted, productivity rises, and people’s roles shift from performing tasks to directing how machines perform them. Hybrid roles break down as follows:

- People–agent roles, which include teachers, engineers, and financial specialists whose work could be enhanced by digital and AI tools. These pay an average of \$74,000 per year and account for about one in five US workers.
- People–robot roles, found in maintenance and construction, involve machines that add strength and precision to human efforts. About 81 percent of these work hours involve physical tasks, and annual pay averages \$54,000. Fewer than one in a hundred US workers hold these jobs.
- People–agent–robot roles, found in transportation, agriculture, and food service, combine all three forms of labor in roughly equal measure. About 43 percent of the work hours involve physical tasks, and annual pay averages \$60,000. Roughly 5 percent of US workers are employed in these roles.

This analysis reflects the current US task mix and what is technically possible with today’s technologies rather than a forecast of what will happen.

The mix of activities will evolve as technology advances and companies adapt their workflows. The distribution of roles across work archetypes also differs by economy and industry. For example, in regions where manufacturing is more prevalent, people–robot roles may be more common than in economies that rely more heavily on services.

Regardless of where one sits, collaboration between people and intelligent machines is likely to deepen. The illustrations below offer examples of how this might work in practice (Exhibit 4).

Exhibit 4

## Reimagining solar operations.

### Illustrative workflow: Facility inspection and repair

#### AI-powered drone

Performs visual and thermal inspections to identify faults, soiling, and other anomalies, sharing insights and data with field technicians, AI agents, and other robots.

#### AI-powered agent, system performance

Monitoring system health 24/7 using data from robots and sensors. Predicts component failures and recommends maintenance schedules for robots and field technicians.

#### AI-powered agent, energy optimization

Optimizes generation and grid interaction in real time. Automates decisions about when to store or dispatch power and schedule maintenance to maximize efficiency.

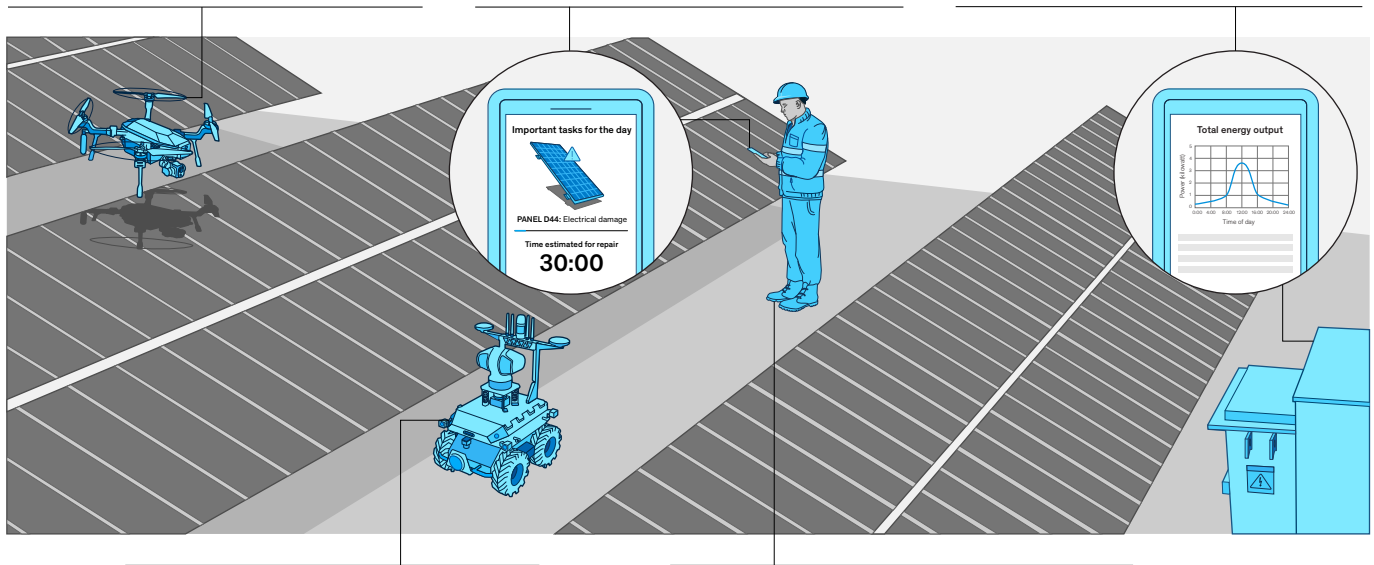

#### AI-powered rover

Cleans panels, removes vegetation, and performs minor mechanical repairs. Operates mostly autonomously, reporting progress to AI agents and field technicians.

#### Field technician

Oversees AI agents and robots, validating diagnostics and handling complex repairs. Coordinates maintenance plans, trains robots through demonstration, and ensures safety, compliance, and performance across all systems.

## Redesigning building materials store operations.

### Illustrative workflow: Order fulfillment and handling

#### AI-powered agent, inventory management

Manages real-time inventory data, including proactively coordinating with suppliers, managing restocks, and scheduling logistics.

#### Store manager

Leads customer engagement by building relationships, understanding project goals, and providing tailored advice on material selection—supported by insights from AI agents.

#### AI-powered agent, personalized recommendations

Analyzes design specifications, budget constraints, and client objectives to generate optimal material recommendations and project plans.

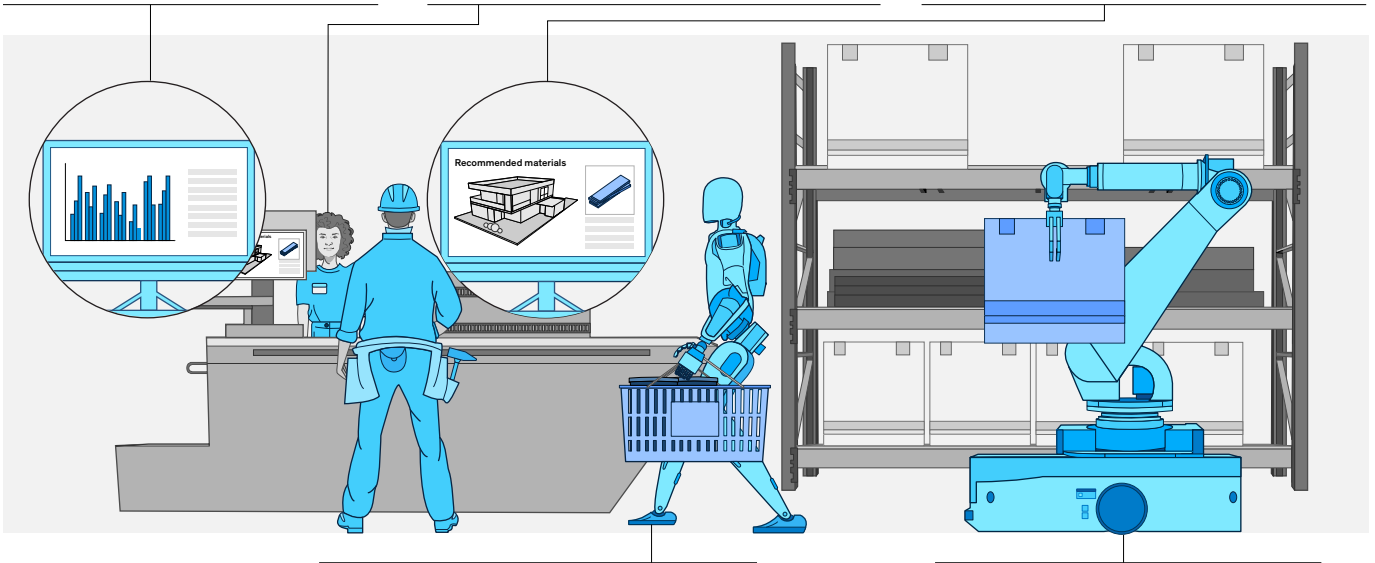

#### AI-powered humanoid

Autonomously retrieves smaller items—like paints, tools, and brushes—to the store front, assisting both staff and customers in locating and moving materials.

#### AI-powered mobile manipulator

Safely transports heavy materials like wooden panels and packages from the warehouse to the customer pickup area or vehicle.



# Human skills will evolve, not disappear, as people work closely with AI

Employers hire workers for their skills. The skills they need evolve as technology and ways of working change. AI accelerates this shift.

To understand how AI could reshape demand for human skills, we analyzed job postings, which offer the most up-to-date view of what employers are seeking.<sup>15</sup> Lightcast data, widely used by labor economists, provide a detailed and consistent record of the language employers use to describe roles and skills. While postings reflect hiring intentions rather than the actual work people do, they offer the most comprehensive picture of skill demand.

From this source, we identified roughly 6,800 skills cited frequently in more than 11 million job postings, providing a representative snapshot of the US labor market.<sup>16</sup> We then examined how employer requirements differ across occupations.<sup>17</sup>

Our analysis shows that nearly all occupations have at least one highly disrupted skill—defined as being in the top quartile of change by 2030—and that a third of occupations will see more than 10 percent of their skills highly changed.

We also find that employers now expect a broader and more specialized mix of skills across nearly all occupations. A core set of eight high-prevalence skills—communication, management, operations, problem solving, leadership, detail orientation, customer relations, and writing—remains essential across industries. Demand for AI fluency, the ability to use and manage AI, is rising faster than demand for any other set of skills.

## **Skill requirements have become more specific and specialized over time**

The number of distinct skills associated with each occupation has risen on average to 64 from 54 a decade ago, reflecting greater specificity in how employers describe roles.<sup>18</sup> Higher-wage fields tend to require more skills and greater specialization. Job postings for data scientists and economists, for example, list more than 90 unique skills, compared with fewer than ten for motor-vehicle operators.

Higher-wage jobs that require more skills tend to place greater emphasis on management, information, and digital skills. Lower-wage roles focus on hands-on work, operating equipment, and providing care and assistance (Exhibit 5).

Even within a single field—software development, for example—the skills required for similar-sounding jobs can differ sharply. Python developers, AI engineers, and C++ developers share fewer than half of their required skills, reflecting how technology drives specialization.

Because skills are becoming increasingly specific and work is evolving rapidly—with some roles disappearing, others changing, and new ones emerging—adaptability and ongoing learning are essential.

## Skills demanded by employers vary by type of occupation.

Skill distribution in the US, by occupation group,<sup>1</sup> %

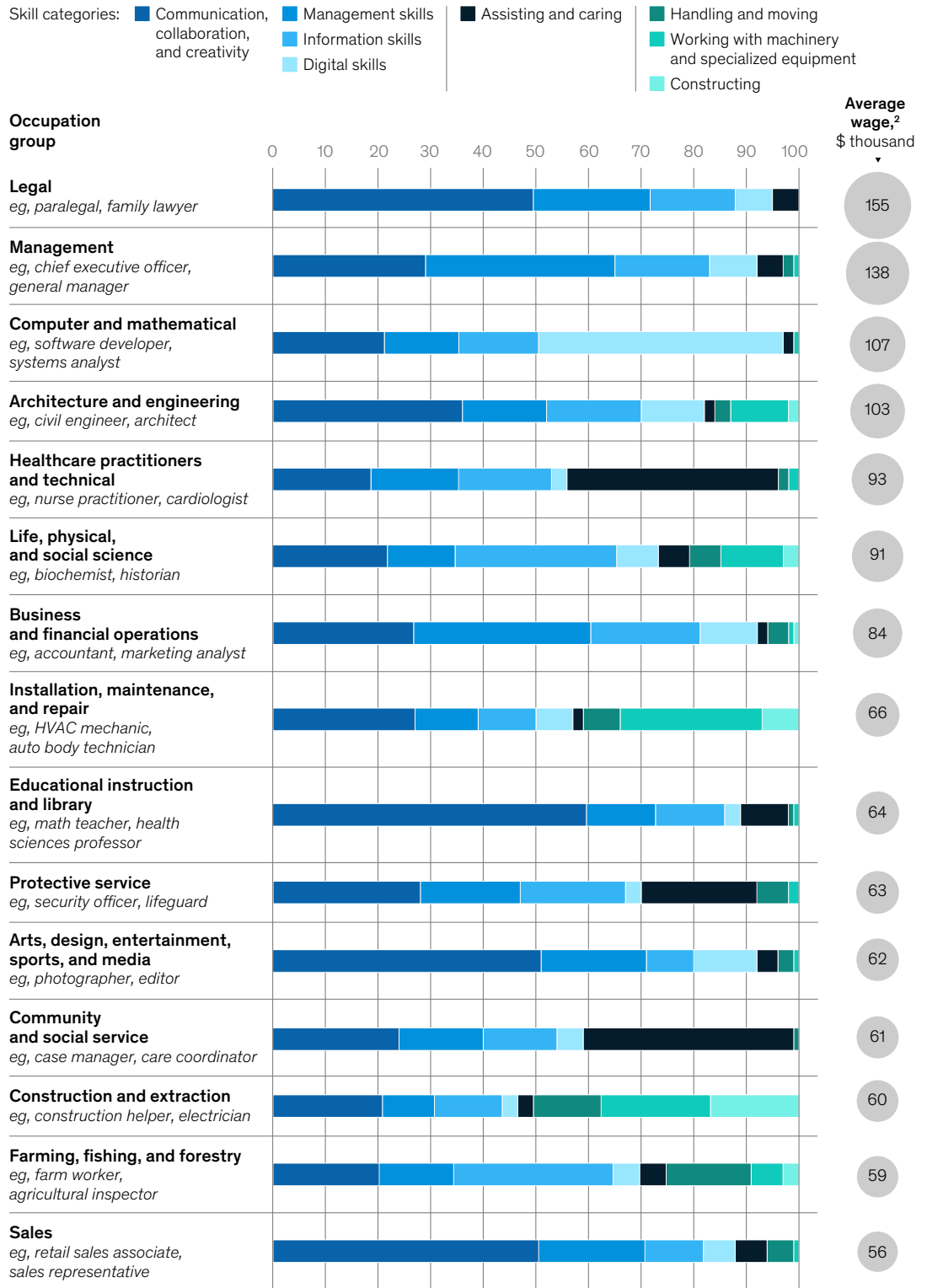

## Skills demanded by employers vary by type of occupation.

Skill distribution in the US, by occupation group,<sup>1</sup> %

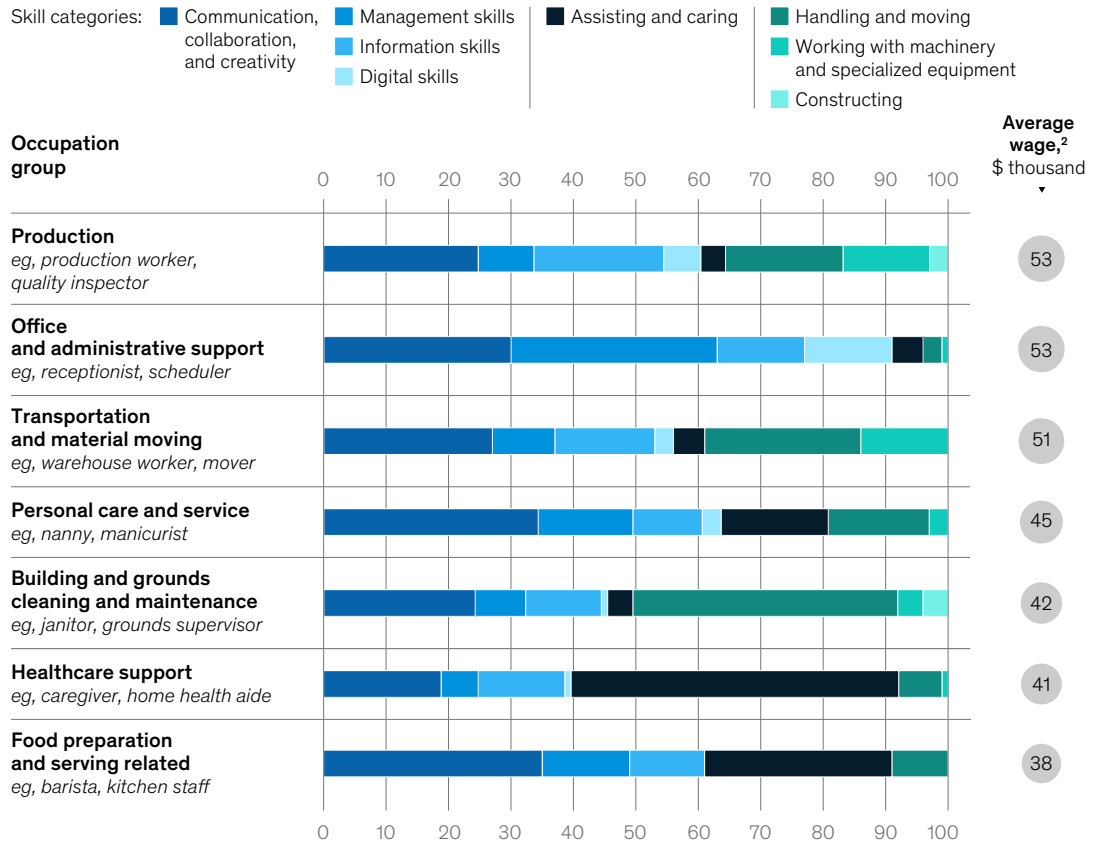

<sup>1</sup>Takes all skills with >5% frequency for all occupations in occupation group, weighted by occupation employment (eg, 49% of all skills used across all occupations in the legal occupation group are related to communication, collaboration, and creativity).  
<sup>2</sup>An occupation group's average wage is weighted by the number of workers in each occupation.  
 Source: Lightcast; US Bureau of Labor Statistics; McKinsey Global Institute analysis

McKinsey & Company

## The speed of technological change raises the importance of transferable skills, including eight high-prevalence ones

Each wave of technology has changed what workers do. The difference today is speed. Until 2023, the need for AI-related skills grew at roughly the same pace as for cloud computing, cybersecurity, and other digital skills. After the rise of generative AI, it accelerated sharply: Nearly 600 new skills appeared in job postings over the past two years—about one-third of the total added in the past decade—many of which are tied to AI and its enabling technologies.

This rapid churn heightens the value of transferable skills. Despite growing specialization, a core set of eight high-prevalence skills—among them communication, customer relations, writing, problem solving, and leadership—has stayed relevant across industries and wage levels.

These skills form the connective tissue of the labor market and are key to workforce development. Building them makes workers more adaptable and better prepared for change. Their application is likely to evolve as people work more closely with AI-powered agents and robots, a theme we explore below.

Many other skills are also transferable across occupations. For example, more than half of the skills required for account executives also appear in 175 other occupations. These range from similar sales positions to roles in marketing and human resources. The overlap allows companies to widen their talent pipelines by drawing from adjacent roles or redeploying employees with similar skills.<sup>19</sup> For workers, it opens pathways to new—and often more people-centric—positions that build on existing strengths (Exhibit 6).

Exhibit 6

### Skill adjacencies could create new talent mobility pathways for companies and individuals.

**Example comparison: Skill overlap and technical automation potential of occupations in the US, compared with an account executive**

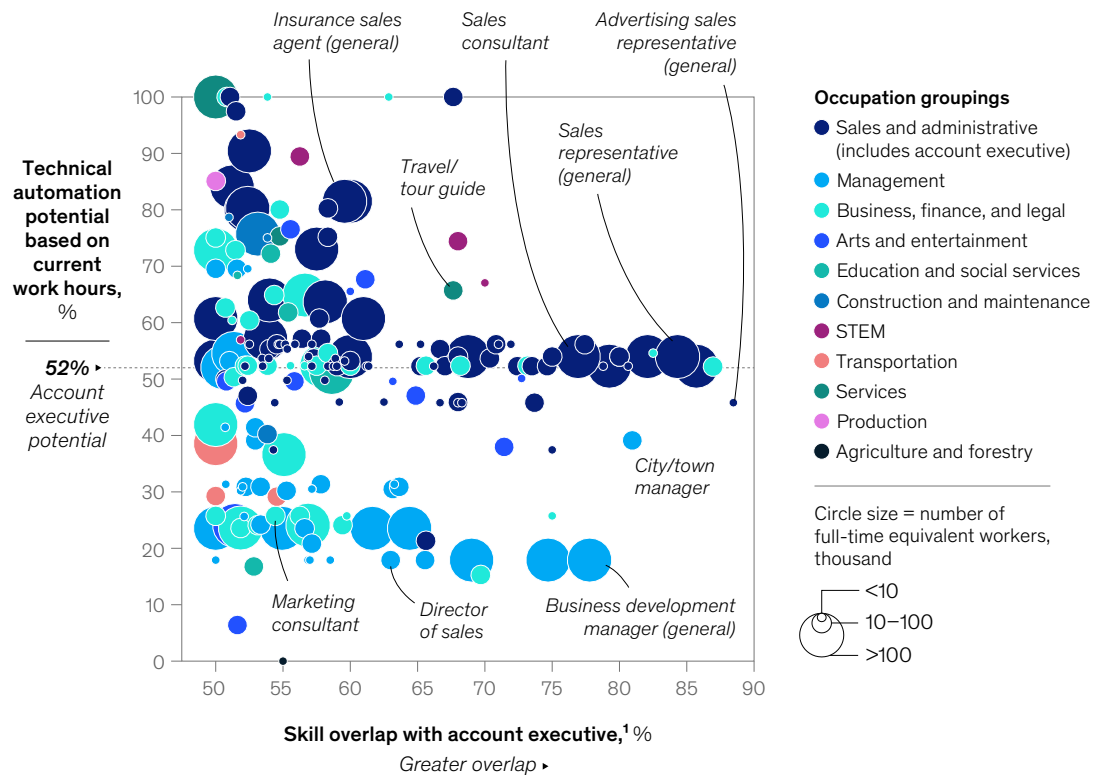

<sup>1</sup>Skill overlap is calculated as the percentage of an occupation's skills shared with another occupation. Source: Lightcast; US Bureau of Labor Statistics (2024); McKinsey Global Institute analysis

## Demand for AI fluency is growing faster than any other skill

As AI technology matures, demand for related skills is spreading beyond development roles. Demand for AI fluency jumped nearly sevenfold in the two years through mid-2025. It is now a job requirement in occupations employing about seven million workers. Demand for technical AI skills—building and deploying AI systems—has also grown, albeit at a slower pace (Exhibit 7).<sup>20</sup>

Exhibit 7

### Demand for AI fluency and technical AI skills rose between 2023 and 2025.

**Number of employees in US occupations where an AI-related skill was listed in at least 5% of postings, million**

Occupation type: ■ STEM<sup>1</sup> ■ Non-STEM

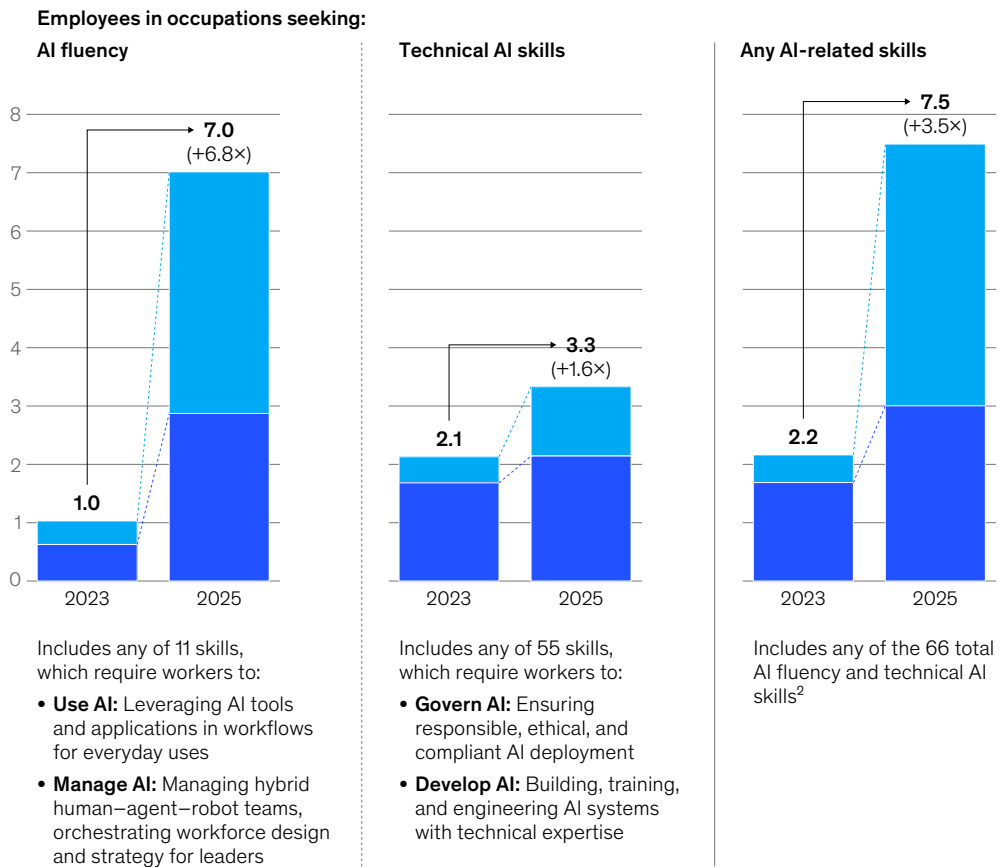

<sup>1</sup>Includes the following Standard Occupational Classification (SOC) occupation groups: computer and mathematical occupations; architecture and engineering occupations; life, physical, and social science occupations; and healthcare practitioners and technical occupations.

<sup>2</sup>In many cases, non-STEM occupations may require technical AI skills if they are managers of STEM occupations (eg, chief technology officer, director of engineering, technical product manager).

Source: Lightcast; US Bureau of Labor Statistics; McKinsey Global Institute analysis

McKinsey & Company

So far, however, most AI skill demand today is concentrated in a few fields. Three-quarters of all AI skill demand in the United States is found in three occupational groups: computing and mathematics; management; and business and finance (Exhibit 8). The rest comes from ten other groups in which the technology is starting to become more prominent, including architecture and engineering; installation, maintenance, and repair; and education. Demand for AI-related skills remains limited in nine other occupational groups such as construction, transportation, and food service, which together account for about 40 percent of the workforce and fall below the median income.

Exhibit 8

## Seventy-five percent of today's demand for AI skills comes from three occupation groups.

Employees in US occupations where an AI-related skill was listed in at least 5% of postings<sup>1</sup>

Occupation type: ■ STEM ■ Non-STEM

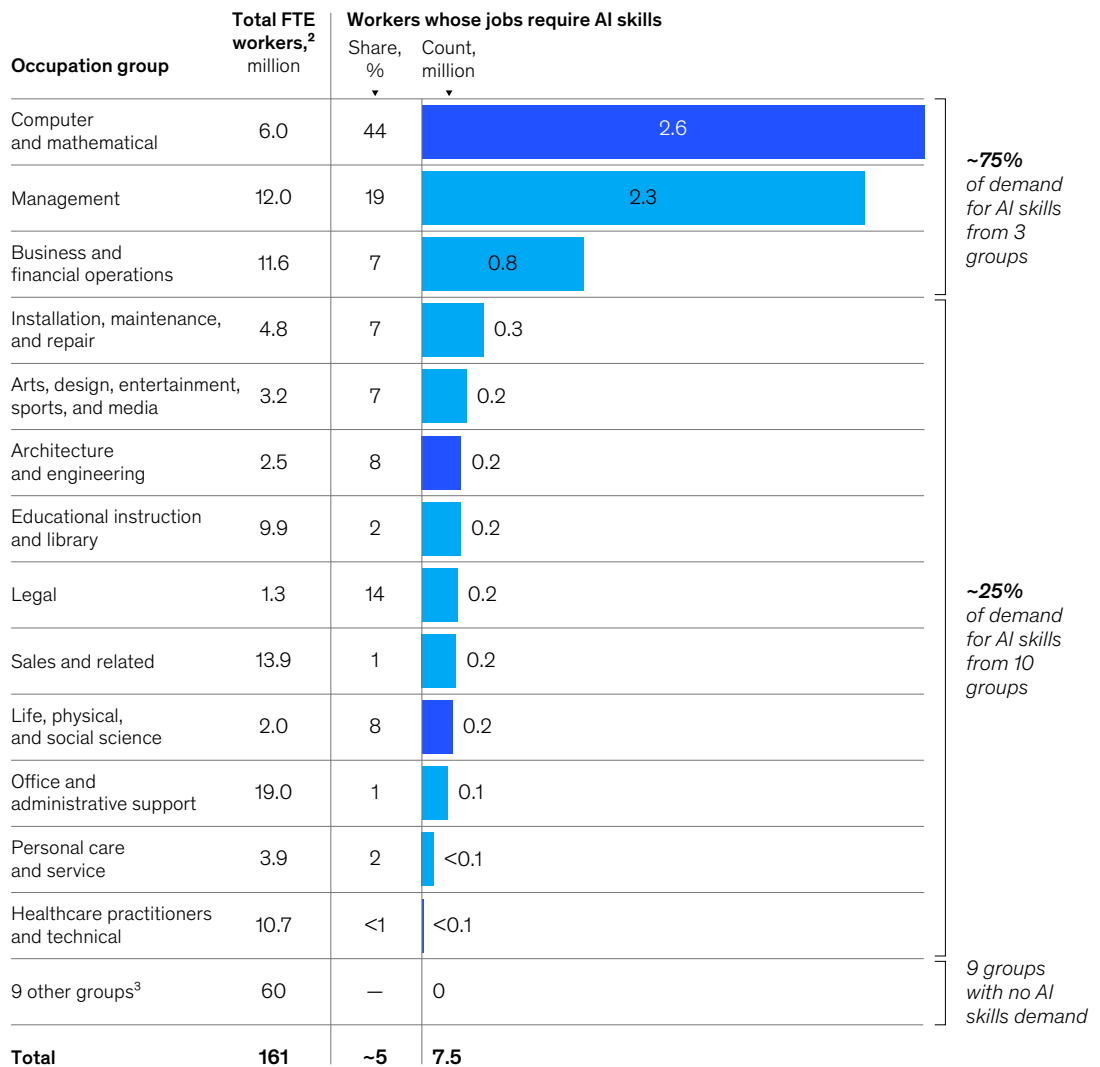

<sup>1</sup>Includes only skills Lightcast categorizes as "artificial intelligence and machine learning" or "natural learning processing."

<sup>2</sup>Full-time-equivalent workers.

<sup>3</sup>Construction and extraction; transportation and material moving; production; protective service; building and grounds cleaning and maintenance; food preparation and serving related; healthcare support; community and social service; farming, fishing, and forestry.

Source: Lightcast; US Bureau of Labor Statistics; McKinsey Global Institute analysis

While the core demand is still concentrated, AI's influence is beginning to ripple outward. Employers are increasingly seeking more AI-adjacent capabilities such as process optimization, quality assurance, and teaching—skills employed to redesign work with AI, supervise and verify AI systems, or train people to use them.

Meanwhile, the number of mentions in job listings is falling for skills that machines already perform well or significantly enhance—research, writing, and simple mathematics—though these skills remain essential for much of the workforce (Exhibit 9).

Exhibit 9

## AI-related skills are the fastest-growing category in demand.

### Change in the number of US occupations with job postings mentioning each skill subcategory, 2023–25<sup>1</sup>

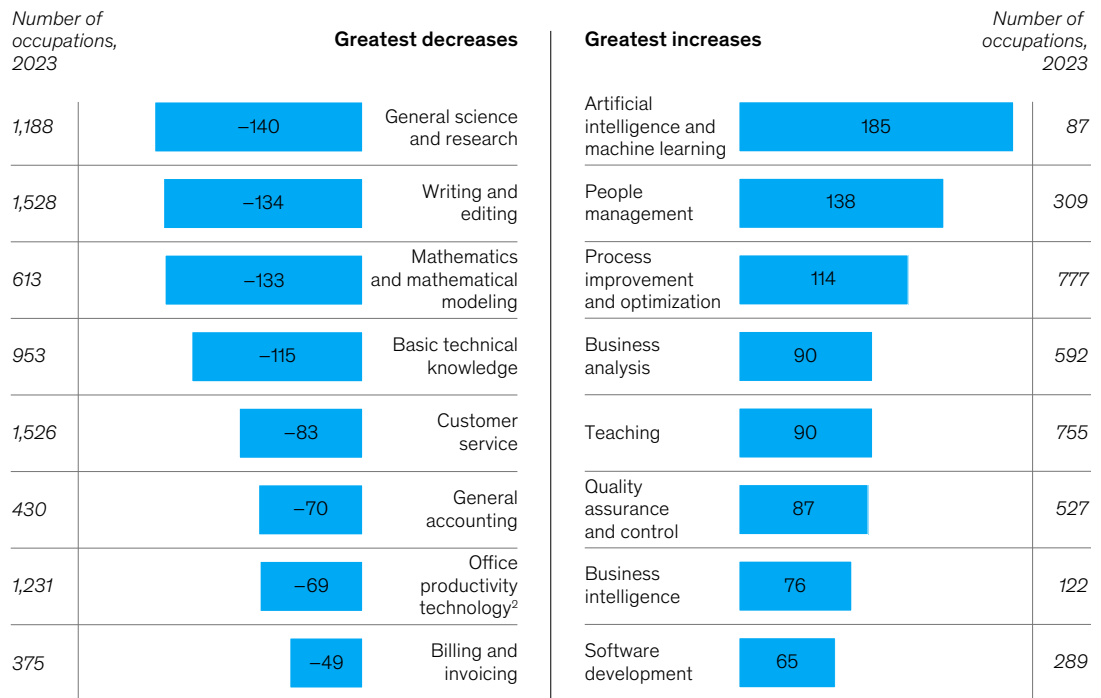

<sup>1</sup>At least one skill associated with the subcategory is listed in >5% of job postings for a given occupation.

<sup>2</sup>Decline in this subcategory is driven by skills associated with office software such as word processing tools and spreadsheets.

Source: Lightcast; McKinsey Global Institute analysis

McKinsey & Company

## Most human skills will remain relevant, but AI will change how they are used

Our analysis finds that roughly 72 percent of skills are required both for work that could be done by AI and for work that must be done by people (Exhibit 10). For details, see sidebar “How we assess skill exposure to automation.”

A small set of skills is likely to remain uniquely human. These are rooted in social and emotional intelligence such as interpersonal conflict resolution and design thinking, which depend on empathy, creativity, and contextual understanding and will be challenging for machines to replicate.

At the other end of the spectrum are skills likely to become largely AI-led, including data entry, financial processing, and equipment control. In these areas, people will step back from hands-on work to focus on design, validation of results, and exception handling—making sure AI agents and robots run properly as they operate mostly on their own.

Between these poles lies a broad middle ground where people and AI work side by side. Here a skills partnership is emerging: Machines handle routine tasks while people frame problems, provide guidance to AI agents and robots, interpret results, and make decisions. The work blends collaboration and oversight, as humans bring judgment and contextual understanding that machines still lack.

### Sidebar

#### How we assess skill exposure to automation

Our assessment of how skills could change integrates four inputs: employment in various occupations, detailed work activities of each occupation, the skills relevant for each DWA, and the McKinsey automation adoption model estimating the automatability of each DWA. Our model draws full-time-equivalent (FTE) and average wage data for about 800 occupations from the BLS; data from O\*NET on about 2,000 DWAs linked to occupations; and data on roughly 34,000 skills linked to about 1,800 occupations from Lightcast.

We filtered the skills data set to include only those appearing in more than 5 percent of job postings for each of the approximately 1,800 Lightcast occupations, narrowing the sample to about 7,000 skills. We then mapped the BLS occupation, wage, and FTE data onto the Lightcast occupations.

Next, we mapped all skills to their corresponding DWAs within occupations, creating about 3.4 million occupation–DWA–skill mappings. We used OpenAI’s GPT-4o model through the asynchronous chat-completions endpoint. Each occupation–DWA–skill pairing was processed as an individual API call with a standardized prompt to ensure consistent outputs. To verify quality, we first created a manually built 1,000-cell template for the generative model to replicate and infer from. We conducted iterative quality testing—spot-checking outputs, refining prompts, and rerunning samples—until the model produced reliable and consistent mappings.

To examine potential future implications of AI on skills, we used two lenses.

First, we classified the skills into three groups—people-led, AI-led, and shared—based on the technical automation potential of their associated work activities. For each skill, we calculated the total time spent in the United States on these mapped DWAs and identified the share of that time

associated with automatable versus non-automatable work. Skills with 55 percent or more of their time in non-automatable activities were classified as people-led, while those with 55 percent or more in automatable activities are AI-led. AI-led skills were further distinguished as agent- or robot-led depending on whether the underlying work activities required physical capabilities. All other skills were categorized as shared.

Second, we assessed the potential skill-change level by 2030, calculated from the average automation adoption projected in 2030 for specific occupation–DWA combinations mapped to that skill, weighted by time spent. The analysis relies on the midpoint automation-adoption rate for 2030 for each DWA, drawn from the latest (2025) update of the McKinsey automation model.

## Most skills are used across both automatable and non-automatable work activities.

Distribution of skills in the US, by technical automation potential<sup>1</sup>

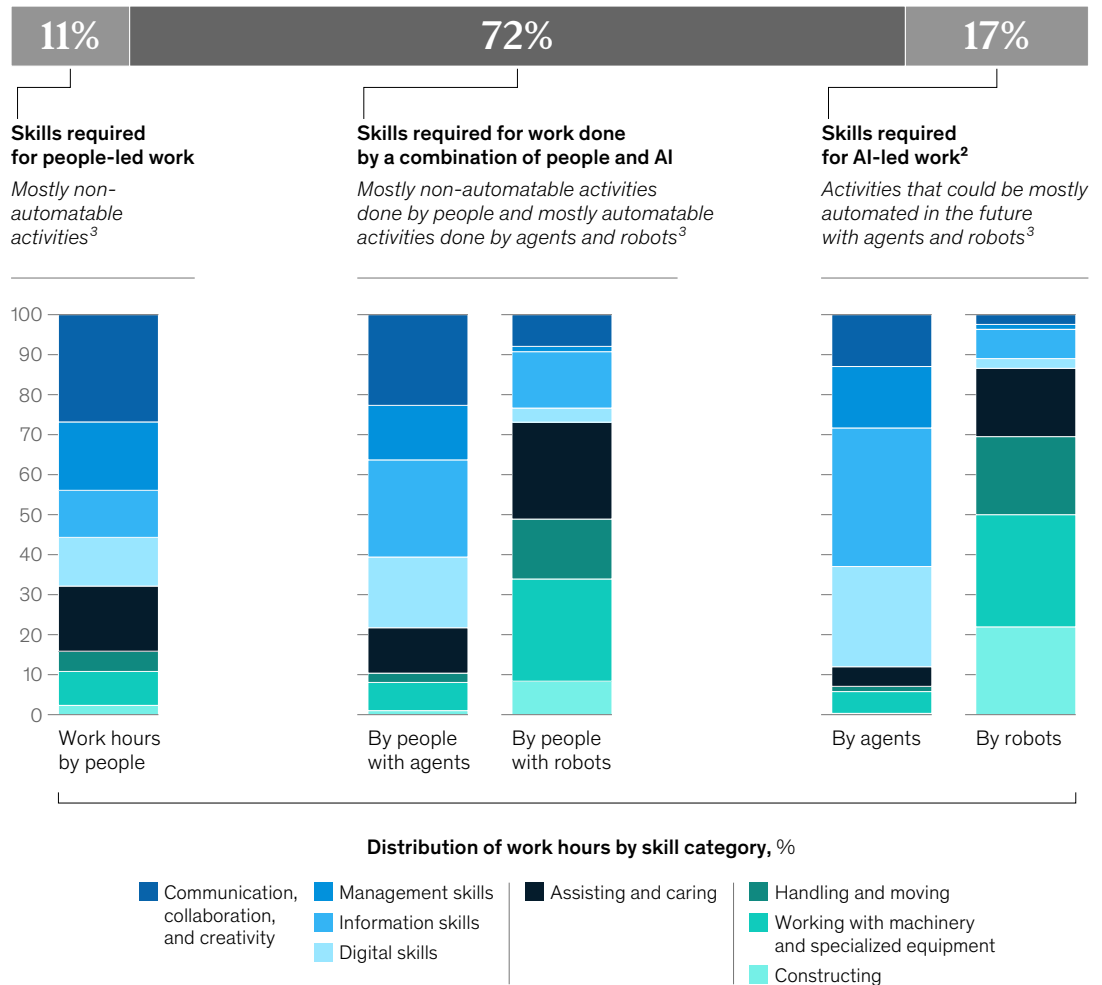

Note: In this research, we use "agents" and "robots" as broad, practical terms to describe all machines that can automate nonphysical and physical work, respectively. Many different technologies perform these functions, some based on AI and others not, with the boundaries between them fluid and changing. Using the terms in this inclusive way lets us analyze how automation reshapes work overall.

<sup>1</sup>Share of ~6,800 skills that are mapped to work activities and occupations. Skills that can be used in more than 80% of either automatable or non-automatable work activities are considered AI- or people-led skills, respectively.

<sup>2</sup>The 17% figure includes skills across agent-led activity (14%), robot-led activity (1%), and activity shared by agents and robots (2%).

<sup>3</sup>Time spent is aggregated at the activity level, based on technical automation potential in 2024 and the capabilities required to perform the activity (ie, cognitive only vs physical and cognitive).

Source: Lightcast; O\*NET; Current Population Survey, US Census Bureau; McKinsey Global Institute analysis



McKinsey & Company

The eight high-prevalence skills described earlier fall largely within this middle ground. They remain relevant but will evolve as people, agents, and robots take on different aspects of the same work (Exhibit 11).

Exhibit 11

## The application of skills will change as people shift to working with and managing AI.

### Example shifts in high-prevalence skills in the US among people, agents, and robots

Skill	Relevance across occupations, <sup>1</sup> %	 PEOPLE, AGENTS, AND ROBOTS will collaborate on	 AGENTS AND ROBOTS will	 PEOPLE will
Communication	99	Drafting, presenting and interpreting information	Generate content and accelerate data flow	Refine nuance and storytelling
Management	94	Planning projects, tracking progress, and optimizing workflows	Automate scheduling and monitor metrics	Coach and lead hybrid teams
Operations <sup>2</sup>	84	Forecasting demand, scheduling resources, and tracking performance	Execute routine tasks and optimize efficiency	Design smarter processes and strategize
Problem-solving	83	Analyzing data, diagnosing causes, and testing solutions	Identify patterns and propose options	Interpret findings and make judgments
Leadership	83	Setting vision, aligning stakeholders, and managing change	Drive change and support decision-making	Guide and motivate teams
Detail orientation	80	Checking compliance, verifying accuracy, and ensuring quality	Run quality checks and flag anomalies	Audit outputs and validate outcomes
Customer relations	80	Responding to inquiries, resolving narratives, and nurturing trust	Route requests and handle routine queries	Strengthen loyalty and build relationships
Writing	76	Generating reports, crafting narratives, and refining content drafts	Produce drafts and propose revisions	Refine text and craft story

Note: In this research, we use “agents” and “robots” as broad, practical terms to describe all machines that can automate nonphysical and physical work, respectively. Many different technologies perform these functions, some based on AI and others not, with the boundaries between them fluid and changing. Using the terms in this inclusive way lets us analyze how automation reshapes work overall.

<sup>1</sup>Relevance is based on percentage of all occupations with frequency threshold >5% for the skill.

<sup>2</sup>Operations is a skill that involves managing and overseeing the day-to-day activities of a business or organization. This includes managing resources, processes, people, and technology to ensure efficient and effective operations.

Source: Lightcast; McKinsey Global Institute analysis

McKinsey & Company

## The Skill Change Index shows widespread shifts in skills by 2030

Among the 100 most in-demand skills, the effects of AI will differ widely. People-focused skills such as coaching face the least exposure to automation, while manual and routine skills like invoicing face the most. Skills such as quality assurance fall near the middle of the distribution—areas where AI is changing how people use skills rather than replacing them outright.

To gauge the extent of these shifts, we developed the Skill Change Index (SCI), a time-weighted measure of each skill's potential exposure to automation in different adoption scenarios. The SCI shows where the most significant shifts in skills are likely to occur.

In the midpoint scenario, roughly one-quarter to one-third of work hours tied to the 100 most in-demand skills could be automated by 2030. For instance, about 28 percent of the work associated with quality assurance could be carried out by machines (Exhibit 12).

Exhibit 12

### Our Skill Change Index assesses how automation exposure varies across skills.

Skill Change Index, % (0–100 scale)

○ Circles = index values of top 100 skills<sup>1</sup>

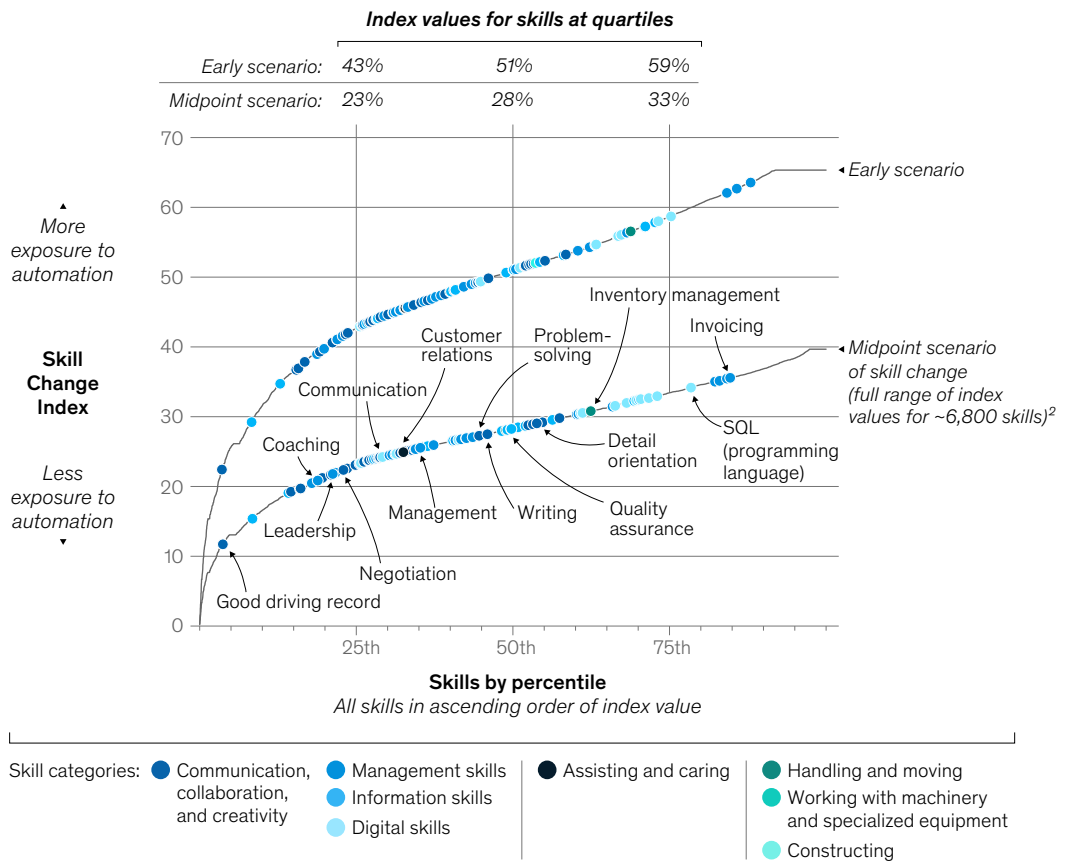

<sup>1</sup>Based on projected 2030 midpoint and early scenarios of automation adoption of activities associated with skills, aggregated across occupations using employment-based weighting.

<sup>2</sup>Based on ~6,800 skills. We excluded skills that could not be linked to detailed work activities within occupations.

Source: Lightcast; US Bureau of Labor Statistics; McKinsey Global Institute analysis

In a faster-adoption scenario, exposure rises sharply. Under this trajectory, the most affected skills among the top 100 could reach 60 percent, while about half of the work hours associated with quality assurance could be automated.

Across the broader set of 7,000 skills, exposure remains uneven. Digital and information-processing skills rank highest on the SCI, reflecting AI's growing proficiency in data handling and analysis. By contrast, assisting and caring skills are likely to change the least (Exhibit 13).

Exhibit 13

## Digital and information skills are expected to experience the most change by 2030, while assisting and caring skills see the least.

### Skill distribution in the US, by position on Skill Change Index<sup>1</sup>

Automation exposure: ■ Low (bottom quartile) ■ Moderate (middle 2 quartiles) ■ High (top quartile)

Skill category	Distribution, %	Skill examples, by automation exposure	
		Lower	Higher
Digital skills	11 (Low), 47 (Moderate), 42 (High)	Agile coaching, certified scrum product ownership	Programming languages, word processing software
Information skills	18 (Low), 53 (Moderate), 29 (High)	Advocacy, policy development	Data analysis, research, quantitative modelling
Working with machinery and equipment	18 (Low), 55 (Moderate), 27 (High)	Drill press skills, tower climbing	Ability to set up, operate, and maintain machines
Constructing	25 (Low), 44 (Moderate), 31 (High)	Shingling, window and door installation	Spray painting, paving, concrete pouring
Communication, collaboration, and creativity	28 (Low), 58 (Moderate), 14 (High)	Conflict resolution, relationship management	Report writing, analytical thinking, troubleshooting
Management skills	29 (Low), 49 (Moderate), 22 (High)	Leadership, coaching, stakeholder management	Prioritization, invoicing skills, cash management
Handling and moving	29 (Low), 42 (Moderate), 29 (High)	Animal care skills, landscaping skills	Manufacturing process knowledge, hand tools
Assisting and caring	54 (Low), 36 (Moderate), 10 (High)	Basic first aid, patient care, peer support	Food preparation, medication inventory management

<sup>1</sup>Based on around 6,800 skills, excluding skills that could not be linked to detailed work activities within occupation groups. Source: Lightcast; McKinsey Global Institute analysis

The SCI reveals three broad paths for how skills may evolve.

Highly exposed skills—those in the top quartile of the index—are more likely to decline in demand. These are often specialized skills, such as accounting processes and programming in specific languages, that AI can already perform well.

Skills in middle quartiles are more likely to evolve, changing in nature and application rather than simply rising or falling in demand. These are often transferable skills that combine human judgment with digital tools; AI fluency itself is one of these. As workers collaborate with AI, they apply skills like writing and research in new ways rather than being made obsolete.

Finally, low-exposure skills—those in the bottom quartile—are likely to endure. Often grounded in human connection and care, such as leadership and healthcare skills.

Over time, the overall demand for skills will depend on how the mix of jobs in the economy evolves and on how rapidly organizations adopt AI and other technologies. As adoption accelerates, some skills that are only partially automatable today may become more exposed, while entirely new forms of work and skills may emerge.



# Entire workflows can be reimaged around people, agents, and robots

AI-powered automation could unlock \$2.9 trillion of economic value in the United States by 2030, according to our midpoint adoption scenario.<sup>21</sup> Realizing these gains requires more than automating individual tasks. It will mean redesigning entire workflows so that people, agents, and robots can work together effectively. (See sidebar “How we estimate the economic value of AI.”)

## **Reimagining workflows is key to capturing the economic potential of AI**

Workflows—multistep processes involving collaboration, information exchange, and decision-making—form the backbone of how organizations operate. Most were designed for a pre-AI world, so applying AI to individual tasks within these legacy processes is unlikely to deliver the productivity gains now possible.

This may explain why relatively few businesses report tangible benefits from AI so far. Nearly 90 percent of companies say they have invested in the technology, but fewer than 40 percent report measurable gains.<sup>22</sup> The gap may reflect the fact that many projects are still in pilot or trial phases or that organizations are applying AI to discrete tasks rather than redesigning entire workflows. In banking, for example, this would be the difference between offering employees access to a chatbot for ad hoc use and deploying custom agents alongside people in a reimaged process to approve, process, and manage loans more efficiently and deliver better customer service. Unlocking larger productivity gains from AI will require reimagining workflows along the lines of the latter, rather than taking a task-based approach.

We analyzed 190 business processes across the US economy to identify where the greatest opportunities may lie. About 60 percent of potential productivity gains are concentrated in workflows related to sector-specific domains—activities at the core of each industry. In manufacturing, these include supply chain management; in healthcare, clinical diagnosis and patient care; and in finance, regulatory compliance and risk management. Additional gains come from cross-cutting functions such as IT, finance, and administrative services that support every sector (Exhibit 14).

## Sector-specific domains represent 60 percent of economic value of AI and automation, with the rest in cross-cutting domains.

Economic value of sector and cross-cutting domains in the US, 2030 midpoint scenario of automation adoption<sup>1</sup>

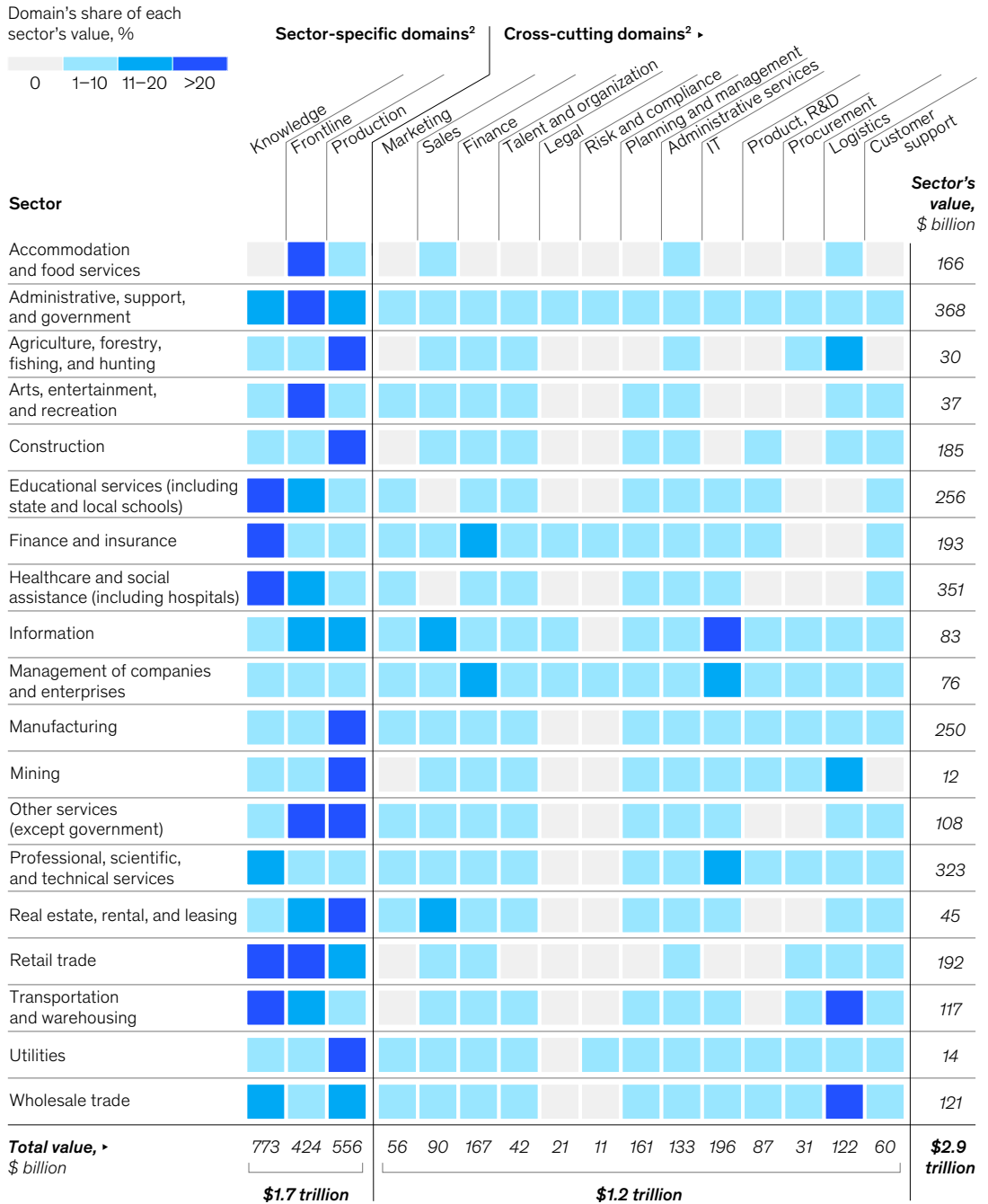

<sup>1</sup>Sized by multiplying the occupation-level automation adoption (in the midpoint scenario of 2030) by number of full-time equivalents and annual wage in 2024.  
<sup>2</sup>Most "cross-cutting domains" are support functions, but some are also core business roles in a relevant sector, eg, finance professionals in finance and insurance, tech workers in information, logistics roles in transportation and warehousing.  
 Source: O\*NET; US Bureau of Labor Statistics; Current Population Survey, US Census Bureau; McKinsey Global Institute analysis

## Sidebar

### How we estimate the economic value of AI

**The economic value** represents the value of US work hours that could be automated by 2030 in our midpoint adoption scenario across sectors and functions—about \$2.9 trillion in total (exhibit).

The calculation begins with technical automation potential, or the maximum share of today's work that could be automated given current technological capabilities. This measure increases as the technical frontier advances. For example, our model assigns \$1.4 trillion of current potential to recent advances in generative AI, while the remaining \$1.5 trillion reflects automation capabilities that existed earlier, such as traditional machine learning.

Both figures reflect the economic value realized by 2030 based on a modeled pace

of adoption, which typically lags behind what is technically possible. Adoption is influenced by the time required to integrate solutions; the relative cost of technology and labor; and other factors such as customer acceptance, labor laws, and workforce skills.

Our estimate covers paid work activities performed by the US workforce. Hours worked refers to time spent on specific activities in today's economy. The total economic value assumes that roughly 27 percent of current work hours will be automated by 2030—the midpoint between early- and late-adoption scenarios. The share of work hours potentially automated varies across sectors, from 20 percent in healthcare to 31 percent in manufacturing.

For each occupation within each sector, we apply the midpoint automation-adoption rate to today's hours worked and wages, then aggregate the results across sector-function intersections based on occupational composition. We divide the resulting value

between agents and robots, depending on the capabilities required for each activity. When physical capabilities are required, the value is attributed to robots; when only nonphysical—cognitive and social and emotional—capabilities are required, it is attributed to agents. These estimates do not account for the additional value that could be created with hours saved (for example, through new activities), nor do they reflect ongoing operating cost or capital investment costs, or the potential effects of work performed outside current working hours.

In earlier research, we estimated economic potential solely on the basis of technological feasibility, without reference to the time frame over which it might be realized based on adoption rates.<sup>1</sup> Calculated that way, the total economic potential would reach \$6.4 trillion in the United States, based on current levels of technical capability. Globally, the figure would be \$28.7 trillion, up from the earlier projection of about \$26 trillion.

<sup>1</sup> *The economic potential of generative AI: The next productivity frontier*, McKinsey Global Institute, June 2023.

## How we estimate the economic value of AI

Exhibit

### Agents could contribute more than three-quarters of the economic value of AI and automation.

Distribution of agents' and robots' economic value in the US by sector, 2030 midpoint scenario of automation adoption<sup>1</sup>

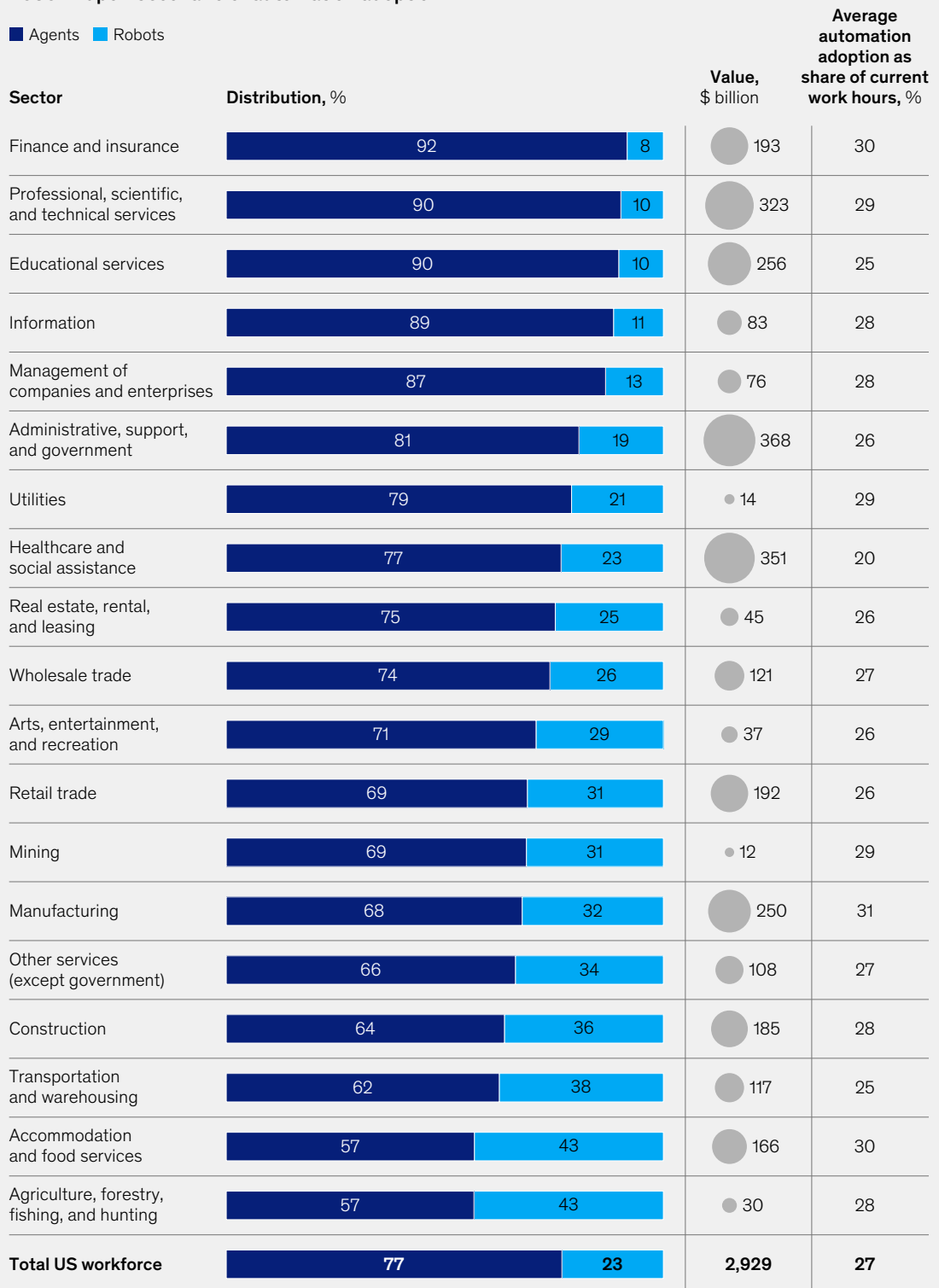

<sup>1</sup>Economic value was calculated using 2024 nominal wage bill and 2030 automation adoption rate in the midpoint scenario. Source: O\*NET; US Bureau of Labor Statistics; Current Population Survey, US Census Bureau; McKinsey Global Institute analysis

In finance and insurance, for example, there are seven key workflows within the IT function (Exhibit 15). Every sector–function combination has its own set of workflows, which represent the critical unit for realizing gains from human–AI collaboration. (See sidebar “An early view of workflows across the US economy” for more examples.)

Exhibit 15

**For each sector, drilling down into a set of specific functions and workflows reveals economic value.**

**Illustration of functions and workflows in the finance and insurance sector**

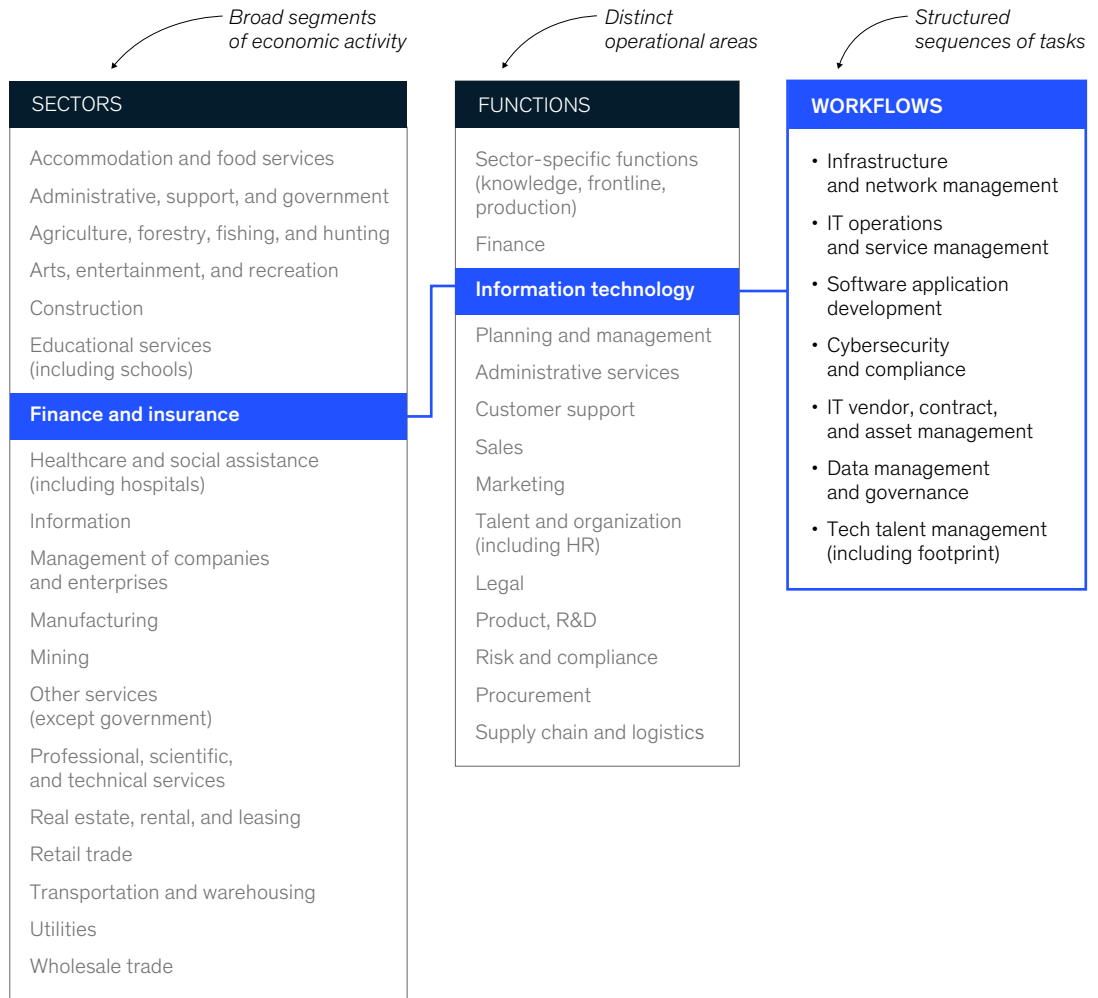

Source: McKinsey Global Institute analysis

McKinsey & Company



## An early view of workflows across the US economy

### OPERATIONAL WORKFLOWS

#### Logistics and supply chain

- Supply and demand forecasting
- Inventory planning and optimization
- Transportation and logistics coordination
- Warehouse and fleet management
- Order fulfillment and handling
- Manufacturing execution and validation
- Process improvement and automation
- End-to-end supply chain optimization

#### Procurement

- Supplier discovery and qualification
- Contract creation, review, and negotiation
- Category management and competitive tendering
- Spend and vendor performance analysis

#### Customer support

- Customer service and technical support
- Call routing, escalation, and behavioral handling
- Call summarization and post-call insights
- Retention, satisfaction, and experience tracking

#### Product, R&D

- Development and technical execution
- User, market, and requirements research
- Concept design, prototyping, and validation
- Product strategy and road map planning
- Experimentation, testing, and validation
- Launch readiness and life cycle management
- Performance monitoring and iteration
- Innovation pipeline and IP management

### SECTOR-SPECIFIC WORKFLOWS

#### Knowledge services

##### HEALTHCARE

- Patient intake and triage
- Medical chart abstraction
- Provider network design and contracting
- Clinical documentation improvement
- Prior authorization case review
- Lab results interpretation
- Medical research and support

##### EDUCATION

- Individualized education plan development and coordination
- Curriculum design, alignment, and sequencing
- Student academic recordkeeping
- Assessment scoring and analysis
- Learning progress monitoring

##### SCIENTIFIC AND TECHNICAL SERVICES

- Hypothesis development and testing
- Research synthesis and benchmarking analysis
- Archival and documentation retrieval
- Peer review and publication prep
- Knowledge curation and data tagging
- Experimental and data pipeline optimization
- Insight generation and translational synthesis

##### PROFESSIONAL SERVICES (INCLUDING LEGAL)

- Case matter triage and scoping
- Proposal, bid, and deliverable development
- Hypothesis development and testing
- Research synthesis and benchmarking analysis
- Strategic modeling and argument construction
- Insight generation and executive-level communications

##### FINANCE AND INSURANCE (INCLUDING BANKING)

- Consumer account onboarding and Know Your Customer standards
- Wealth management advisory
- M&A deal origination and execution
- Loan application and underwriting
- Treasury and liquidity services
- High-net-worth client portfolio management
- Equity and debt capital markets issuance
- Client pitchbook generation
- Claims review and adjudication
- Case triage and eligibility assessment
- Risk scoring and underwriting analysis
- Policy interpretation and coverage validation
- Fraud detection and investigation
- Provider contract review and negotiation

#### Frontline services

##### FOOD SERVICES

- Order taking and service
- Food preparation and plating
- Kitchen station restocking
- Sanitation logging and compliance

##### PUBLIC SERVICES

- Emergency response dispatch and triage
- Rescue operations
- Disaster and incident response
- Traffic and public event control

##### RETAIL TRADE

- Customer assistance and checkout
- Returns and exchanges
- Loyalty program enrollment
- In-store experience support

##### ARTS AND ENTERTAINMENT

- Exhibit setup and visitor engagement
- Live performance production
- Sound and lighting operation
- Audience services
- Event facilitation and instruction

##### ACCOMMODATION SERVICES

- Hotel check-in and concierge
- Queue and crowd management
- Appointment booking and check-in
- Service delivery
- Post-service checkout and upselling
- Equipment cleaning and station reset

## An early view of workflows across the US economy

## Exhibit

### ■ Production services

#### MANUFACTURING

- Raw material staging and prep
- Machine setup and changeover
- Assembly line production
- Packaging and labeling
- Quality inspection and defect logging
- Production planning and optimization
- Real-time process monitoring

#### AGRICULTURE

- Soil preparation and fertilization
- Seeding and planting
- Irrigation and crop care
- Harvesting and yield collection
- Crop processing and packaging

#### CONSTRUCTION

- Site preparation and equipment staging
- Framing and structural assembly
- Material cutting and fitting
- Concrete mixing and pouring
- Equipment operation
- Construction quality assurance (eg, level checks)

#### MAINTENANCE AND REPAIR

- Preventive equipment maintenance
- Utility system servicing
- Facility inspections and repairs
- Equipment downtime troubleshooting
- Support system inspections
- Machine calibration and diagnostics
- Temporary utility setup and repair
- Remote diagnostics and predictive maintenance

#### MINING AND UTILITIES

- Resource extraction (eg, drilling, mining)
- Raw input handling and pretreatment
- Power generation or refining process execution
- Monitoring and control room operations
- Utility distribution management

Source: McKinsey Global Institute analysis

McKinsey & Company

## From a utility to a bank, early movers are experimenting with AI-embedded workflows

Some organizations are redesigning workflows around AI, offering early evidence of how these transformations look in practice. We identified 80 implementation cases—from pharmaceuticals to banking and sales—and looked closely at several to glean insights from their approaches.

Managers and specialists are increasingly acting as orchestrators and validators rather than executors, while domain experts such as data analysts, underwriters, and engineers partner with agents that perform initial analysis or generate draft outputs. As a result, the most valuable human skills are shifting toward AI fluency, adaptability, and critical evaluation of outputs, enabling people to focus on higher-value work.

We present four cases that illustrate how these changes are unfolding. A technology firm uses AI agents to prioritize sales leads and manage outreach, freeing specialists to spend more time negotiating and building relationships. A pharmaceutical company applies AI to draft clinical reports, reducing errors and accelerating regulatory submissions. In customer service, agents now resolve most routine inquiries, while a regional bank uses them to speed up software modernization.

These deployments illustrate how increasingly specialized agents could reshape entire business processes. They also show that people remain at the center of work because AI still depends on human guidance, interpretation, and quality control.

**Sales case: AI-powered agents enabled specialists to redirect time from routine tasks to selling activities**

A global technology company sought to expand its reach and deepen customer relationships while navigating growing complexity and customer volume. In its traditional model, human sales teams used inconsistent prioritization methods and had limited capacity to tailor outreach to thousands of smaller accounts. As a result, only top prospects received customized attention.

To overcome these limits, the company introduced several AI agents to automate the early stages of the sales process (Exhibit 16). A *prioritization agent* scores and ranks accounts based on public and proprietary data. An *outreach agent* contacts customers, while a *customer response agent* manages follow-ups and categorizes leads as interested, not interested, or uncertain. A *scheduling agent* sets up calls and reminders for high-potential leads. When a case requires human judgment, a *handoff agent* transfers the file to a specialist.

This process expanded outreach and improved conversion rates, delivering a projected annual revenue increase of 7 to 12 percent from new sales, cross-selling, and increased retention. Across sales roles, time saved ranged from 30 to 50 percent. Business development specialists were able to spend more time on strategic engagement—drafting proposals, negotiating partnerships, and building relationships.

Looking forward, this model could be extended by introducing additional agents to support sales. A *coaching agent* could provide real-time feedback to sales teams, while an *admin agent* could act as an assistant, handling routine administrative tasks.

## Redesigning commercial workflows with agents could help sellers reallocate time from routine tasks to selling activities.

Illustration: People-agent collaboration at a global B2B tech company

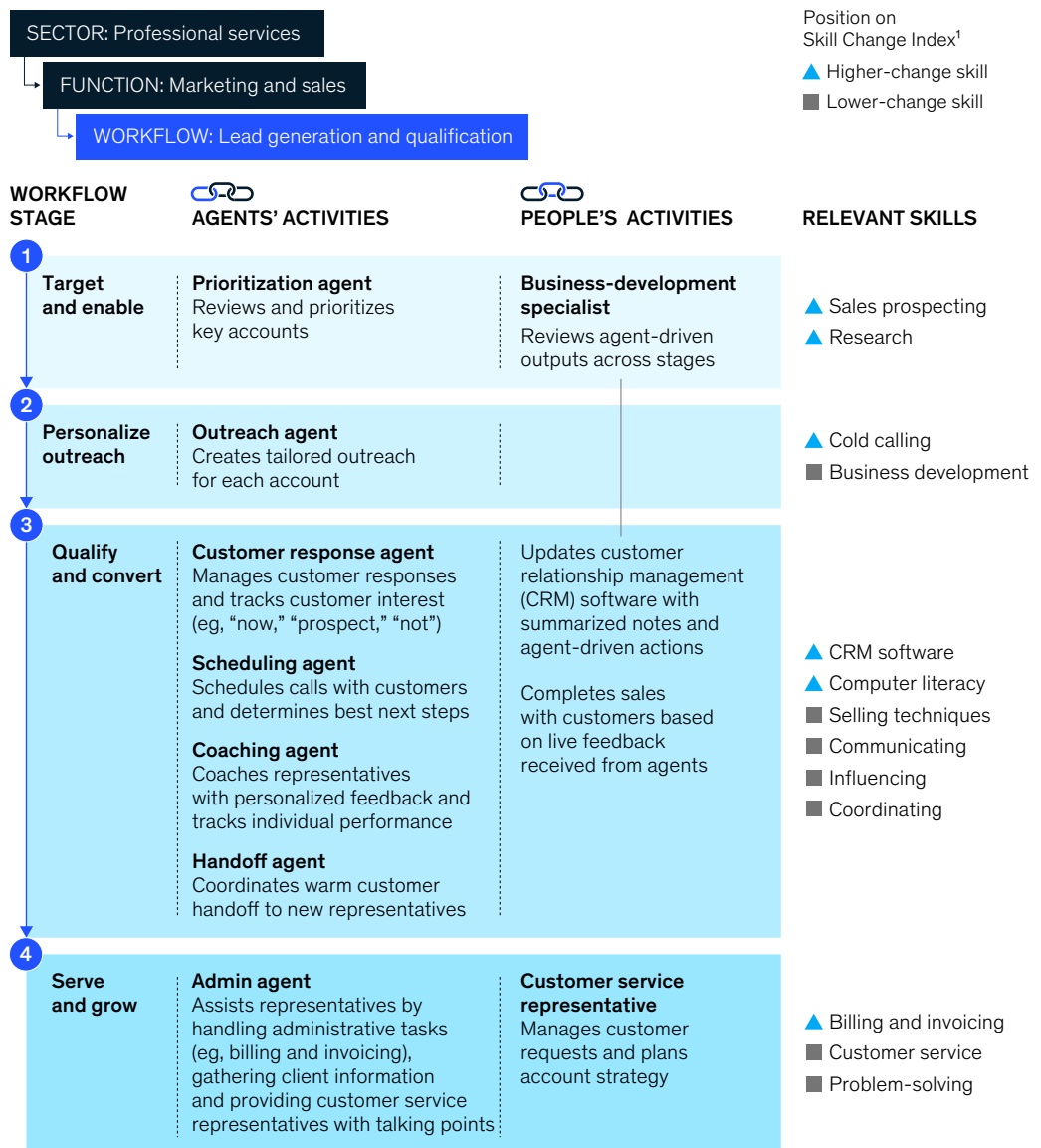

<sup>1</sup>Based on MGI's Skill Change Index (SCI). Lower-change skills are in the first and second quartiles of SCI, while higher-change skills are in the third and fourth quartiles.  
 Source: McKinsey Global Institute analysis

### **Customer operations case: AI agents improved customer experience and reduced cost per call**

A large utility company handles more than seven million support calls each year, even with multiple self-service options available on its app and website. Its interactive voice response system had previously resolved only about 10 percent of inquiries, leaving the rest to human customer-service representatives.

To improve efficiency and customer experience, the company deployed agentic conversational AI across its entire customer base (Exhibit 17). The system includes several agents: an *inbound call agent* that authenticates customers, an *intent identification agent* that determines the purpose of the call, a *call scheduling agent* that manages appointments, and a *self-service agent* that integrates with back-end systems. Together, these now handle roughly 40 percent of all calls, resolving more than 80 percent without human involvement. When escalation is needed, customers are transferred with verified account details and conversation history, ensuring a seamless handoff.

The new process has cut the average cost per call by about 50 percent and increased customer satisfaction scores by six percentage points, driven by shorter waiting times, more consistent handling, and faster resolution. Human representatives now manage more complex, emotionally sensitive, and high-value issues, improving both the quality and the impact of service.

Future applications could go further. A *customer issue identification agent* could monitor systems to detect service interruptions and contact customers proactively, while a *coaching agent* could provide real-time guidance to human representatives during live calls. In such models, AI would handle most routine inquiries while people concentrate on complex or relationship-based issues, supported by continuous insights and automated follow-up. Advanced AI agents could eventually handle 80 to 90 percent of customer inquiries, documenting each interaction and initiating follow-up to ensure continuity and consistency.

## Reimagining service workflows with agents could improve customer experience in issue resolution.

Illustration: People-agent collaboration at a leading utilities firm

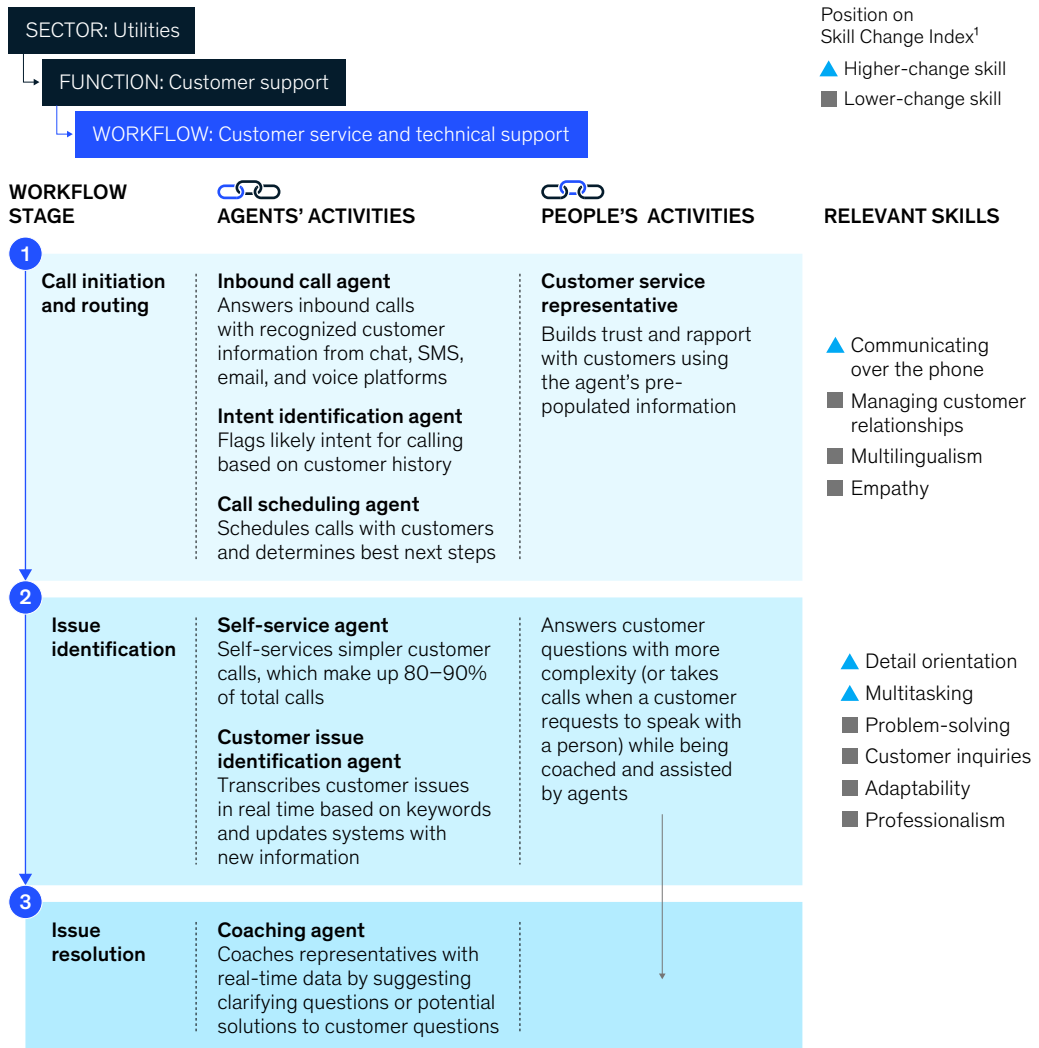

<sup>1</sup>Based on MGI's Skill Change Index (SCI). Lower-change skills are in the first and second quartiles of SCI, while higher-change skills are in the third and fourth quartiles.  
 Source: McKinsey Global Institute analysis

McKinsey & Company

### Medical writing case: Gen AI platform accelerated report drafting and improved accuracy

A global biopharmaceutical company sought to improve its process for drafting clinical study reports, which document safety and efficacy data for new drugs. In the traditional model, medical writers manually compiled study data, drafted lengthy reports, and coordinated multiple review cycles. Limited capacity and long turnaround times constrained the ability to meet growing submission demands.

To improve the speed and quality of clinical study reports, the company developed an AI platform that reconfigures workflows for report writing (Exhibit 18). This AI companion synthesizes structured

## Streamlining clinical study reporting workflows could enhance collaboration between people and agents.

Illustration: People-agent collaboration at a global pharmaceutical company

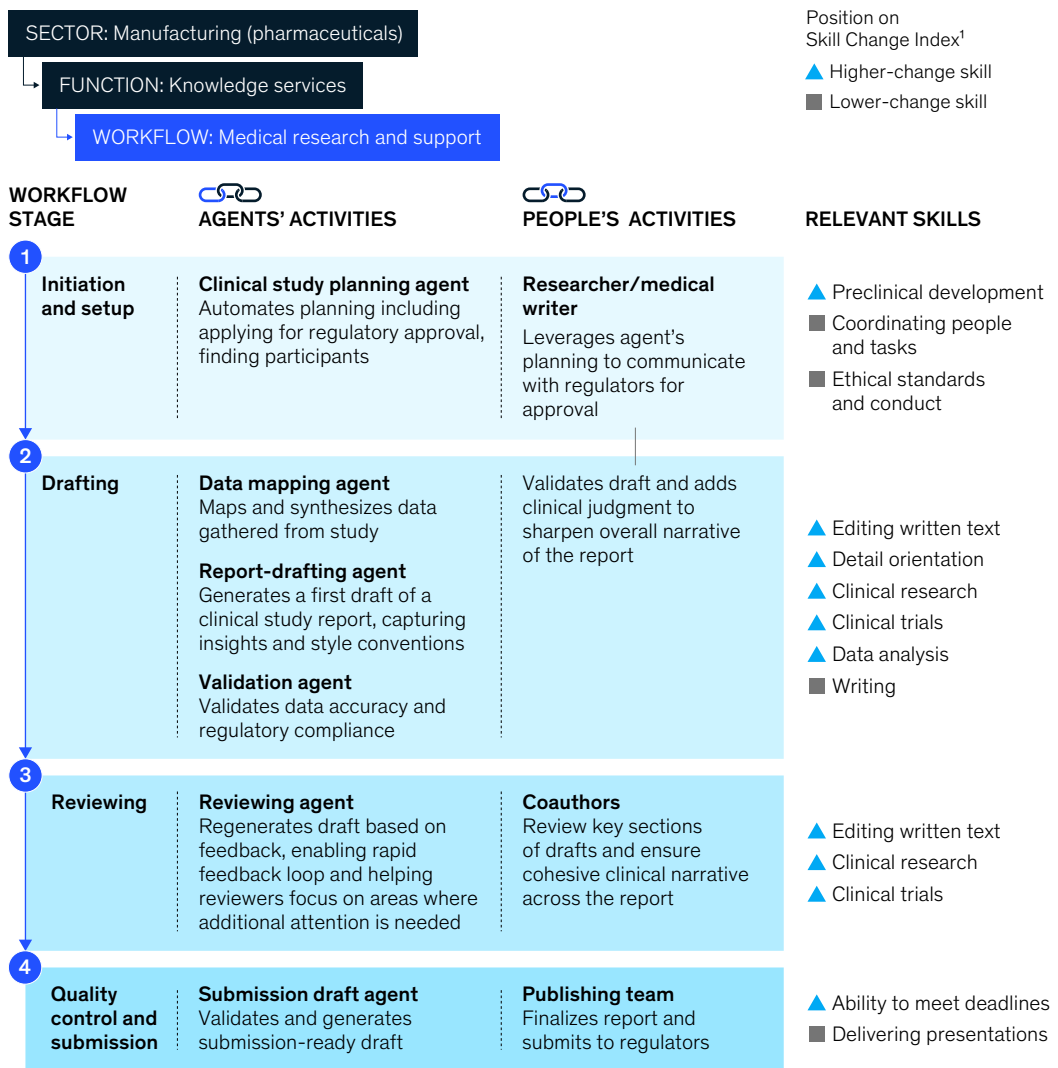

<sup>1</sup>Based on MGI's Skill Change Index (SCI). Lower-change skills are in the first and second quartiles of SCI, while higher-change skills are in the third and fourth quartiles.  
 Source: McKinsey Global Institute analysis

McKinsey & Company

and unstructured study data, generates comprehensive drafts in minutes, applies company style and compliance templates, and self-reviews for errors. These tools shift the medical writers' role from manual drafting to collaborating with AI systems and applying clinical judgment. Writers can regenerate and edit sections of text, review potential issues, and validate data against source materials to ensure accuracy and regulatory compliance.

Early data indicate substantial efficiency gains. Touch time for first human-reviewed drafts dropped by nearly 60 percent, and errors declined by roughly 50 percent. Go-to-market efforts accelerated by weeks when combined with other related processes and technology changes, and further

improvements are expected as writers build AI skills and additional agents are introduced. The company reports that scaling these efforts can be challenging, and a combination of technology and people skills, including resilient data engineering, prompt engineering upskilling, and bold organizational leadership, is key.

Looking ahead for life science companies, agents could be leveraged to support key stages of clinical research, from study planning through to submission. A *clinical study planning agent* could help assemble trial protocols, a *data mapping agent* could analyze and synthesize data, and a *report drafting agent* could produce full drafts. A *validation agent* could then check for compliance, and a *reviewing agent* could scan for errors. Finally, a *submission draft agent* could help generate regulator-ready documents. Applied across the research cycle, these tools could shorten timelines by several months.

### **IT modernization case: AI agents streamlined code migration and shifted human roles to orchestration**

A regional lender used AI agents to modernize its banking application for small and medium-size enterprises. The aim was to update various programming languages to speed up internal development. The project would previously have required months of work, large budgets, and extensive engineering capacity for manual documentation, code refactoring, and testing of millions of lines of code.

To accelerate the process, the bank launched a pilot using AI agents for multiple modernization tasks (Exhibit 19). An *assessment agent* scans legacy code bases identifying dependencies, while a *functionality agent* generates the target-state architecture. A *coding agent* migrates code to new frameworks and performs automated tests. Developers collaborated with 15 to 20 agents each, verifying and refining outputs to ensure architectural integrity, compliance, and functional accuracy. The modernization also shifted applications from desktop to mobile, on-premises to cloud, and monolithic to microservice architectures.

As AI agents took on most of the repetitive execution, the focus of human work shifted toward planning, orchestration, and testing. Early results show up to 70 percent code accuracy.

Following the pilot module, the bank now plans to extend the use of agents to the entire modernization effort. It estimates that this could reduce required human hours by up to 50 percent. A *modernization planning agent* could coordinate the process, supported by *quality assurance agents* and *testing agents*.

## Automating IT modernization workflows could elevate related roles to focus more on orchestration.

Illustration: People-agent collaboration at a regional bank

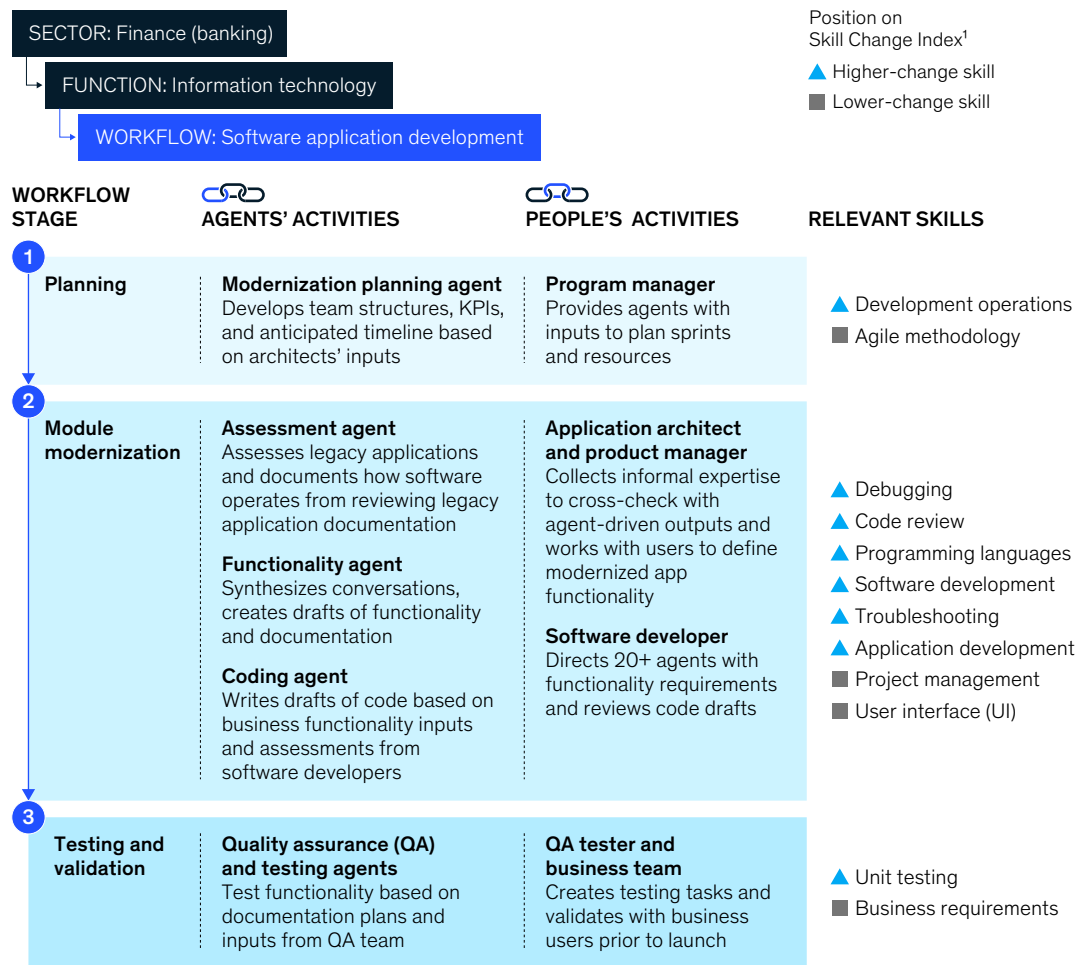

<sup>1</sup>Based on MGI's Skill Change Index (SCI). Lower-change skills are in the first and second quartiles of SCI, while higher-change skills are in the third and fourth quartiles.  
 Source: McKinsey Global Institute analysis









McKinsey & Company

## AI is reshaping managerial work and skills

Our case studies show that as AI takes on more analytical and decision-support tasks, the nature of managerial work is shifting from supervising people to orchestrating systems in which people, AI agents and robots collaborate. This change allows managers to redirect time to higher-value work involving skills such as influencing and mentorship, while also demanding greater technical fluency (Exhibit 20). For example, a sales manager might spend more time coaching teams to use AI-driven insights and strengthen relationships, while a customer service manager might oversee a hybrid workforce of people and AI agents, training both AI systems and staff to improve service.

## Leadership and management skills will need to change in the era of AI.

### Example shifts in leadership and management skills in the US among people, agents, and robots

Skill	Position on Skill Change Index, quartile	 PEOPLE, AGENTS, AND ROBOTS will collaborate on	 AGENTS AND ROBOTS will	 PEOPLE will
<b>Prioritization</b>	 High level of change	Sequencing and balancing tasks across shifting priorities	Sequence tasks dynamically based on people guidance	Balance stakeholder needs with AI sequencing
<b>Decision-making</b>	 Medium level of change	Gathering insights and evaluating options for strategic choices	Simulate scenarios and suggest options	Apply judgment to AI-simulated scenarios
<b>Planning</b>		Designing plans, assigning resources, and monitoring progress	Reallocate schedules and resources at scale	Align stakeholders around AI outputs
<b>Coordinating</b>		Aligning teams, resolving conflicts, and sustaining momentum	Orchestrate workflows and flag conflicts	Resolve conflicts that AI flags in workflows
<b>Budgeting</b>		Tracking spend, forecasting revenues, and managing allocations	Monitor spending and predict outcomes	Adjust priorities using AI spending predictions
<b>Accountability</b>		Documenting results, justifying decisions, and ensuring integrity	Generate audit trails and evidence for review	Interpret AI audit trails to model integrity
<b>Innovation</b>		Brainstorming, building, and testing new concepts and prototypes	Generate concepts and simulate prototypes to test	Test AI-generating concepts with creativity
<b>Coaching</b>	 Low level of change	Observing performance and identifying growth opportunities	Surface insights from performance data	Tailor feedback and motivation from AI insights
<b>Influencing</b>		Building trust, shaping perceptions, and aligning stakeholders	Analyze sentiment and suggest influence strategies	Shape narratives informed by AI analysis
<b>Mentorship</b>		Guiding careers and sharing expertise for development	Analyze conversations for growth signals	Build relationships enriched by AI analysis

Source: McKinsey Global Institute analysis

McKinsey & Company

Across industries, companies are finding that the biggest gains come from redesigning entire workflows rather than automating individual tasks. Doing so requires new operating models, data foundations, and skill pathways for people as their collaboration with agents and robots deepens. In the next chapter, we examine how leadership could evolve to guide this transformation.



# Leadership is crucial as agents and robots reshape work and the economy

AI adoption is reshaping how organizations operate, creating new ways of working built around the strengths of people, agents, and robots. Managing this transition will require business leaders to make deliberate choices about its pace and purpose, and to work with other institutions to ensure that workers are well prepared.

## Key questions for business leaders

For businesses, embedding AI successfully depends on recognizing the enduring importance of people. This is as much a practical concern as an ethical one. As technology takes on more tasks, the judgment and oversight people provide will be even more vital to keeping organizations on course. Work will be organized differently: Employees will need retraining as workflows are reshaped around what people and intelligent machines do best, and performance measures will need to reflect contributions from both. The questions below highlight some of the choices and trade-offs leaders face in implementing AI.

### Are you reimagining your business for future value?

Early AI efforts often aim to improve existing workflows rather than rethink them. Larger gains come from redesigning processes entirely. Building for future value means looking several years ahead and working backward to identify which roles, skills, and structures may need to change in relation to AI. Leaders must choose where they invest in major redesigns now versus refining current models for nearer-term gains.

### Are you leading AI as a core business transformation?

AI will touch nearly every function. Leaders can approach it as either a technology project or a broader business transformation. Delegating responsibility to the IT department may speed implementation, but lasting change and real strategic advantage will depend on visible commitment from senior leadership and sustained attention to how AI affects people and business across the organization.<sup>23</sup>

### Are you building a culture of experimentation and learning?

Implementing AI involves uncertainty, especially at the start. Organizations that test and adapt quickly tend to learn fastest. This depends on a culture that supports curiosity, risk-taking, learning from setbacks, and collaboration. Changing culture is difficult but essential for transformation on the scale AI is likely to require.<sup>24</sup>

### **Are you building trust and ensuring safety?**

AI changes how businesses stay accountable and maintain oversight. The focus is shifting from checking individual outputs to setting clear policies, validating AI logic, dealing with exceptions, and determining when human involvement is most needed. The challenge is to keep the right balance, maintaining enough oversight to manage risk and ensure safety without limiting efficiency and innovation.<sup>25</sup>

### **Are you equipping your managers to lead teams of people, agents, and robots?**

AI is redefining what it means to manage. Routine supervision may be automated, freeing managers to focus on coaching, influencing, and orchestrating hybrid teams of people, agents, and robots. They will also play a key role in testing for bias, validating performance, and upholding integrity. As automation reduces direct control, staying accountable for outcomes may become more challenging. New performance metrics and feedback systems will be needed to assess human and machine contributions and how they interact.

### **Are you preparing your workers for new skills and roles?**

Companies will need to decide how to use capacity freed up by AI—whether to reinvest it in developing people and higher-value work or to focus on greater efficiency and cost reduction. Most will do some of both. Managing this shift means identifying which roles can evolve and giving employees clear, skill-based pathways to grow into them.

AI makes continuous learning and training even more important to organizational strength. As jobs change and skill needs evolve faster, helping workers understand how their skills transfer to new types of work will make both people and businesses more resilient. AI fluency will need to extend across all levels of the organization. Companies can use digital tools, hands-on projects, and coaching to build these skills, while partnerships with other organizations and institutions can expand access to learning and open new opportunities.

## **Key questions for institutions**

Periods of economic disruption often force societies to strengthen the systems that help people adapt. Since the Industrial Revolution, nations have expanded education, training, and social safety nets. In the United States, the New Deal and the GI Bill built modern social infrastructure, while the digital revolution extended inclusion through online learning and telehealth.<sup>26</sup> The coordinated response to the COVID-19 pandemic showed how quickly institutions can mobilize when livelihoods are at stake.

The rise of AI may call for similar renewals. Public, private, and civic institutions can lead by example in retraining people and expanding opportunity. The questions that follow invite leaders to rethink how education and job mobility can evolve in the age of AI.

### **How can education and training keep pace?**

Education will play a pivotal role as skill needs evolve. Foundations of AI fluency—competencies such as critical thinking, questioning results, challenging assumptions, and recognizing bias or error—should be developed from primary school onward so people learn to use and guide these technologies effectively.

Curricula could be redesigned to combine technical knowledge with transferable human skills such as adaptability, analytical thinking, and collaboration. This approach could help prepare workers for a more fluid job market. Universities might integrate AI across disciplines, while vocational and community colleges expand training in skilled trades.

AI could also support more personalized and continuous learning. As demand for reskilling grows, investments in lifelong learning will have to be made. Education systems and employers may need to work more closely together, using shared programs, flexible models, earn-as-you-learn apprenticeships, and faster credentialing, to help people move across jobs and industries.

**What systems are needed to ensure that transferable skills lead to new opportunities?**

As AI transforms work, many people will need to move into entirely new occupations. Transferable skills will be essential to make those shifts, but they will matter only if the labor market can recognize and reward them. Clear definitions of skills, trusted ways of demonstrating ability—through testing or verified credentials—and better matching platforms could make this possible. Building links between employers, schools, and credentialing institutions could expand access to work and opportunity.

**How can local economies and communities respond?**

The impact of AI will vary widely across industries and regions. Understanding those differences through data is the first step toward effective action. With a clear picture of where change is happening, industry groups, educators, workforce agencies, and unions can work together on training and job-transition strategies that fit local needs.

---

The partnership between people, agents, and robots is already taking shape as businesses embed the technologies in their workflows, changing skill profiles for jobs in many industries.

Today's technologies offer vast opportunities to increase productivity and enhance human skills and will continue to advance. How work evolves depends on choices made now. Investing in workers and their skills—not just in technology—will be decisive in expanding human potential and ensuring that the benefits of AI are widely shared.

# Glossary of terms

<i>Concept</i>	<i>Definition</i>
<b>Adoption</b>	The deployment of AI and automation technology into real work activities and workflows within an organization or labor-force context, determining how much of the automation potential is captured, how fast, and how broadly.
<b>Agents</b>	Machines that perform work activities in the digital world, augmenting or substituting a person's nonphysical capabilities (e.g., natural language generation, social and emotional reasoning, creativity).
<b>AI-powered agents</b>	Agents with AI embedded, allowing them to act more autonomously and orchestrate workflows; also known as agentic AI.
<b>AI-powered robots</b>	Robots with AI embedded, allowing them to act more autonomously and orchestrate workflows.
<b>Artificial intelligence (AI)</b>	The ability of software to perform tasks that traditionally require human intelligence, potentially augmenting or substituting people's capabilities.
<b>Capabilities</b>	Physical or nonphysical abilities that support the application of skills, assessed based on human levels of performance required to perform work activities. Nonphysical capabilities include cognitive (e.g., natural language, logical reasoning, creativity, navigation) and social and emotional capabilities.
<b>Generative AI</b>	Applications of AI that take unstructured data as inputs and generates unstructured data through foundation models (i.e., large artificial neural networks trained on vast amounts of varied data).
<b>Nonphysical work</b>	Work that involves cognitive or social/emotional capabilities rather than physical movement, such as problem-solving, information processing, creating, or collaborating with others.
<b>Occupations</b>	A set of jobs that share similar tasks or work activities that can be described in terms of their skills, work contexts, and other qualifications. In the United States, occupations are formally classified using the Standard Occupation Classification system, maintained by the Bureau of Labor Statistics.
<b>Physical work</b>	Work that involves direct interaction with the physical world, requiring motion-based capabilities such as gross motor skills, fine motor skills, and mobility. These tasks typically include operating or moving objects, tools, or machinery, assembling or positioning materials, and performing actions that depend on human strength or dexterity.
<b>Robots</b>	Machines that perform work activities in the physical world, augmenting or substituting a person's physical capabilities (i.e., gross motor skills, fine motor skills, or mobility).
<b>Skills</b>	Knowledge, competencies, and attributes that people deploy to perform work activities, often acquired through formal education, training, or work experience. Lightcast and ESCO provide a market-driven classification system for skills.
<b>Technical automation potential</b>	The share of work hours that theoretically could be automated with certain levels of technical capabilities. We assessed the technical automation potential across the US economy through an analysis of the detailed work activities of each occupation. We used databases published by the US Bureau of Labor Statistics and O*NET to break down about 800 occupations into approximately 2,000 activities, and we determined the capabilities needed for each activity based on how humans currently perform them in work.
<b>Work activities</b>	Observable work behavior that represents what people do to accomplish the objectives of an occupation. In the United States, activities are formally classified by O*NET into detailed work activities (DWAs).
<b>Workflows</b>	A structured sequence of work activities that collectively advance work toward a defined goal, guided by processes (e.g., rules, dependencies, information flows) and involving people and technologies.

# Acknowledgments

This research was led by **Lareina Yee**, an MGI director and senior partner in the Bay Area office; **Anu Madgavkar**, an MGI partner in McKinsey's New Jersey office; **Sven Smit**, MGI chairman and a senior partner in the Amsterdam office; **Alexis Krivkovich**, a senior partner in the Bay Area office; **Michael Chui**, a QuantumBlack senior fellow in the Bay Area office; **Maria Jesus Ramirez**, an MGI senior fellow in the Bay Area office; and **Diego Castresana**, an engagement manager in the New York office.

Many other McKinsey colleagues participated in this research. Francisco Garrido, David Martina and Madhumitha Sivaraj also led the working team. Team members were Tara Alizadeh, Constantin Auersperg, Abby Bloomfield, Anya Chopra, Kelly Han, Xavier Rigby, Bouwe Theijse, Sebastian Vargas, and Julie Wong.

We are grateful to MGI senior editors Brian Blackstone and Jason Clenfield, who helped write and edit the report. Chuck Burke and Laura Mandujano provided expert support with data visualization.

For kindly sharing insights, we thank MGI academic advisers Sir Christopher A. Pissarides, a Nobel laureate in economics and the Regius Professor of Economics at the London School of Economics, and Matthew J. Slaughter, Paul Danos Dean of the Tuck School of Business at Dartmouth. We are also grateful to Luca Vendraminelli, a postdoctoral researcher at the Stanford Digital Economy Lab and the Stanford HAI.

Many McKinsey colleagues gave us valuable input and guidance. We want to thank Brian Anstey, Aamer Baig, Carlos Barreto, Chris Bradley, Oana Cheta, Dago Diedrich, Sandra Durth, Diana Ellsworth, Vinayak HV, Christian Jansen, Lionel Jin, Ani Kelkar, Martin Kellner, Eric Kutcher, Damien Lewandowski, Jeffrey Lewis, Roberto Marchi, Jan Mischke, Stephan Muhlhauser, Daniel Pachtod, Steven Prast, Lucia Rahilly, Roger Roberts, Leandro G Santos, Alok Singh, Gurneet Singh Dandona, Kate Smaje, Jonathan Tilley, Olivia White, Matthew Wilson, and Delphine Zurkiya.

On MGI's publishing team, we would like to thank Rachel Robinson and Rishabh Chaturvedi. In communications, our thanks go to Rebeca Robboy, Suzanne Albert and David Batcheck. Thanks also to Diane Rice on McKinsey's design team. We are also grateful for the collaboration of McKinsey's digital production team, including Mary Gayen, Philip Mathew, and Pooja Yadav.

This report contributes to McKinsey's ongoing research on AI and aims to help business leaders understand the forces transforming ways of working, identify strategic impact areas, and prepare for the next wave of growth. As with all MGI research, this work is independent and has not been commissioned or sponsored in any way by any business, government, or other institution. While we gathered a variety of perspectives, our views have been independently formed and articulated in this report. Any errors are our own.

This report was edited by MGI senior editors Jason Clenfield and Brian Blackstone with data visualizations by Laura Mandujano and Chuck Burke.

# Endnotes

## Introduction

- <sup>1</sup> Our analysis considers a broader range of automation technologies than the narrow definition of agents commonly used in the AI literature, where they are described as systems based on foundation models that perform multistep processes. For more on how we define the term, see the Glossary.
- <sup>2</sup> Our analysis focuses exclusively on paid productive hours in the US workforce, encompassing full-time and part-time work across industries, occupations, and skill levels. We assess only the share of time awake that is spent on work-related activities, totaling roughly 45 percent of waking hours. Our analysis excludes time spent on unpaid tasks and leisure, but agents and robots could be used in related activities to support productivity and personal well-being.
- <sup>3</sup> We calculate the economic value of AI and automation in the United States by multiplying employment, salaries and wages, and estimated automation adoption in the midpoint scenario of 2030 for each occupation. Occupation-level employment and wages are based on 2024 data from the US Bureau of Labor Statistics. For details, refer to the chapter 3 sidebar “How we estimate the economic value of AI” and the technical appendix.

## Chapter 1

- <sup>4</sup> See *The economic potential of generative AI: The next productivity frontier*, McKinsey Global Institute, June 2023.
- <sup>5</sup> We use the terms *agents* and *robots* to describe all machines that automate nonphysical and physical work, respectively.
- <sup>6</sup> The estimate excludes unpaid work and leisure activities.
- <sup>7</sup> See *In search of cloud value: Can generative AI transform cloud ROI?* McKinsey, November 2023.
- <sup>8</sup> Technical automation potential shown is the late scenario of expert estimates. In the early scenario of technical automation potential, agents and

robots could perform 60 to 70 percent of today’s global work hours.

- <sup>9</sup> The supply of radiologists is projected to grow by 26 percent over the next 30 years. See Eric Christensen et al., *Projected US radiologist supply, 2025–2055*, National Institutes of Health, February 2025.
- <sup>10</sup> Heinz-Peter Schlemmer, *Navigating the AI revolution: Will radiology sink or soar?* National Library of Medicine, July 2025.
- <sup>11</sup> Steve Lohr, “Your AI radiologist will not be with you soon,” *New York Times*, May 14, 2025.
- <sup>12</sup> Jeffrey Lin, “Technological adaptation, cities, and new work,” *Review of Economics and Statistics*, Volume 93, Number 2, May 2011.
- <sup>13</sup> We classified each occupation by the share of current work hours that could be performed by people, agents, or robots based on the technical automation potential of underlying activities. Occupations centered on one of the three were labeled “centric”; those mixing two or all three were grouped as “combined” or “hybrid.” See the technical appendix for details on how we defined and constructed these archetypes.
- <sup>14</sup> Average pay for each archetype is based on 2024 wages and salaries data from the US Bureau of Labor Statistics. Non-wage compensation and benefits are not included.

## Chapter 2

- <sup>15</sup> We define “skills” as the knowledge and competencies people use to perform work activities.
- <sup>16</sup> Job postings data for May 2025 provided by Lightcast.
- <sup>17</sup> We grouped and analyzed skills using eight categories from the European Skills, Competences, Qualifications and Occupations (ESCO) taxonomy used in labor-market analysis: assisting and caring; communication, collaboration, and creativity; constructing; digital skills; information skills; management skills; handling and moving; and working with machinery and specialized equipment.

- <sup>18</sup> Includes only skills that appear in more than 5 percent of job postings for any given occupation.
- <sup>19</sup> In the United States, roughly 10 percent of occupations require at least one legally mandated skill, mostly in regulated fields such as healthcare, law, and public services. The remaining roles face fewer legal constraints, enabling faster adoption as technology evolves.
- <sup>20</sup> These figures reflect mentions in job postings, not the actual skills of the people ultimately hired.

## Chapter 3

- <sup>21</sup> We calculate the economic value of work automation in the United States by summing the wages associated with hours that could be automated under our midpoint adoption scenario for 2030. Occupation-level employment and wage data for 2024 are drawn from the US Bureau of Labor Statistics. These figures reflect the economic resources that automation could release and redirect to other productive uses. The scale and nature of this redeployment would determine its effects on GDP, productivity, and employment, although those outcomes are beyond the scope of our analysis.
- <sup>22</sup> “The state of AI in 2025: Agents, innovation, and transformation,” McKinsey, November 5, 2025.

## Chapter 4

- <sup>23</sup> “The state of AI in 2025: Agents, innovation, and transformation,” McKinsey, November 5, 2025.
- <sup>24</sup> “Performance through people: Transforming human capital into competitive advantage”, McKinsey Global Institute, February 2, 2023.
- <sup>25</sup> “The agentic organization: Contours of the next paradigm for the AI era,” McKinsey, September 26, 2025.
- <sup>26</sup> “President Franklin Delano Roosevelt and the New Deal,” Library of Congress, accessed November 10, 2025; and “Servicemen’s Readjustment Act (1944),” National Archives, May 3, 2022.

McKinsey Global Institute

November 2025

Copyright © McKinsey & Company

Designed by the McKinsey Global Institute

[mckinsey.com/mgi](https://mckinsey.com/mgi)

 @McKinsey\_MGI

 @McKinseyGlobalInstitute

 @McKinseyGlobalInstitute

Subscribe to MGI's LinkedIn newsletter,

*Forward Thinking*: [mck.co/forwardthinking](https://mck.co/forwardthinking)